

Operating Instructions

Barrier MHTM™ MicroDrive Access XL / XXL

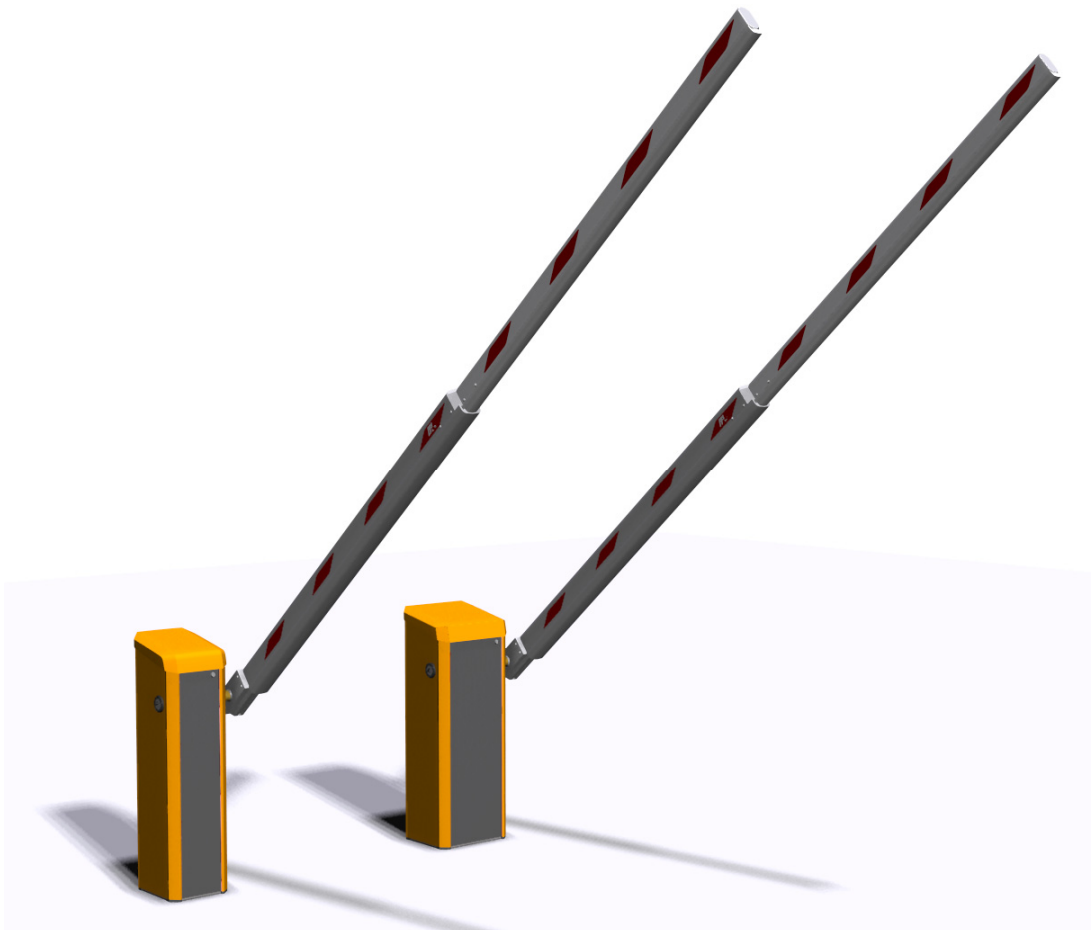

Doc-ID: 5815,0009EN

Version: 00

Translation of the Original Operating Instructions

MAGNETIC Autocontrol GmbH
Grienmatt 20
79650 Schopfheim
Germany

Tel.: +49 (0)7622 695 5
Fax.: +49 (0)7622 695 602
E-Mail: info@ac-magnetic.com
Internet: www.ac-magnetic.com

Contents

1	General	8
1.1	Information regarding the operating instructions	8
1.2	Pictogram explanation	9
1.3	Limitation of liability	10
1.4	Copyright protection	10
1.5	Scope of delivery	11
1.6	Warranty	11
1.7	Disclaimer	11
1.8	Customer service	11
1.9	EC-Declarations of conformity	12
1.10	Environmental protection	12
2	Safety	13
2.1	Intended use of the barriers	13
2.1.1	Intended use for certain road vehicles	13
2.1.2	Barrier, pedestrian traffic impossible	13
2.1.3	Non-intended use	14
2.2	Operator's responsibility	15
2.3	Changes and modifications	15
2.4	Specialists and operating personnel	16
2.4.1	Requirements	16
2.5	Personal protective equipment	17
2.6	Occupational safety and special dangers	17
2.6.1	Danger symbols on the MHTM™ MicroDrive barrier	17
2.6.2	Hazard notes and occupational safety	18
2.7	Danger area	24
3	Identification	25
3.1	Type plate	25
3.2	Type code	26
4	Technical data	27
4.1	Access XL	27
4.1.1	Dimensions and weight	27
4.1.2	Electrical connection	28
4.1.3	Operating conditions	28
4.1.4	Operating times	28
4.2	Access XXL	29
4.2.1	Dimensions and weight	29
4.2.2	Electrical connection	30
4.2.3	Operating conditions	30
4.2.4	Operating times	30

Contents

4.3	Control unit.....	31
4.4	Plug-in module "Detector A–B"	32
4.5	Plug-in module "Radio"	32
5	Design and function.....	33
5.1	Design	33
5.1.1	Access and Parking	33
5.2	Function	34
6	Transport and storage	35
6.1	Safety notes for transport.....	35
6.2	Transport inspection.....	36
6.3	Transport.....	37
6.4	Storage.....	37
7	Design notes for induction loops	38
8	Assembly and installation	42
8.1	Safety	42
8.2	Required steps	43
8.3	Foundation and empty conduits.....	44
8.3.1	Foundation and empty conduits for the barrier Access XL	45
8.3.2	Foundation and empty conduits for the barrier Access XXL.....	47
8.3.3	Foundation and empty conduits for nesting post or light barrier post.....	50
8.4	Assembly and installation of induction loops	52
8.4.1	Directions for the assembly and installation of induction loops.....	52
8.4.2	Induction loops.....	54
8.4.3	Testing induction loops	54
8.4.4	Installing induction loops in bitumen, asphalt, or concrete	54
8.4.5	Installing induction loops under interlocking stone paving	56
8.5	Unpacking	57
8.6	Assemble housing.....	57
8.7	Assemble nesting post or light barrier post.....	59
8.8	Assemble safety light barrier.....	60
8.8.1	Assemble transmitter	60
8.8.2	Assemble receiver	61
8.9	Assemble barrier boom up to 6 metres.....	62
8.10	Assemble barrier boom as of 6 metres	63
8.11	Assemble edge protection	66

8.12	Conversion "left version" – "right version"	67
8.12.1	Converting barrier boom up to 6 metres	67
8.12.2	Converting barrier boom as of 6 metres.....	69
8.13	Check and set the balancing springs in the lever system	72
8.13.1	Setting balancing springs	73
8.13.2	Overview table balancing springs	76
8.13.3	Arrangement of balancing springs	78
8.14	Align barrier housing and post.....	79
8.15	Set nesting post height	80
8.16	Stick on prohibition signs	81
8.17	Check assembly and installation	81
9	Electrical connection	82
9.1	Safety	82
9.2	Installing electrical protective devices	83
9.3	Connecting the power cable	84
9.4	Connect customer's control lines (signalling devices)	86
9.4.1	Connecting safety devices	88
9.4.2	Plausibility check of the safety devices	88
9.4.3	Connecting safety loop.....	89
9.4.4	Connect and test the safety light barriers.....	90
9.4.5	Connecting emergency opening contacts....	91
9.4.6	Digital inputs	91
9.4.7	Digital outputs and output relays	94
9.5	Checking the electrical connection	98
10	Parameterising control unit	99
10.1	Safety	99
10.2	Control elements control unit.....	99
10.3	Displays on the control unit.....	100
10.4	Symbols in the display	101
10.4.1	Control button functions	101
10.4.2	Current state of the barrier	102
10.4.3	Current programme mode	103
10.4.4	Current state of the induction loops	103
10.4.5	Further symbols.....	103
10.5	Parameterising options	104
10.6	Parameterising values	105
10.7	Select programme mode	106
10.7.1	Mode 1: Maintained contact	107
10.7.2	Mode 2: Deadman	108
10.7.3	Mode 3: Pulse control (bistable).....	109

Contents

10.7.4	Mode 4: Two-pulse control	110
10.7.5	Automatic Modes 5 to 8: Drive direction 1 – overview and differences	111
10.7.6	Automatic Modes 5 to 8: Drive direction 2	115
10.7.7	Mode "Service"	116
10.8	Menu "Information" (i)	117
10.9	Programme mode	117
10.10	Menu "Setup"	118
10.10.1	Barrier speed	118
10.10.2	Delays	118
10.10.3	Cut off angle	120
10.10.4	Inputs	120
10.10.5	Outputs	120
10.10.6	Vend count.....	121
10.10.7	Impact settings.....	124
10.10.8	Start-up behaviour	125
10.10.9	Power failure.....	130
10.10.10	Closure by light barrier	131
10.10.11	Master/Slave.....	131
10.10.12	Menu "Language"	132
10.11	Menu "Attachments".....	132
10.11.1	Signal light	132
10.11.2	Boom contact settings	135
10.11.3	Boom locking	136
10.12	Menu "Service".....	136
10.13	Menu "Information".....	136
10.14	Menu "Motor GW (Gateway).....	136
10.15	Menu "Detector 1 (A-B)".....	137
10.15.1	Check the working frequency of the induction loops.....	138
10.15.2	Reconciling and setting the operating frequency of the induction loop.....	139
10.16	Menu "Detector 2 (C-D)"	141
10.17	Menu "Radio control FM"	141
10.18	Factory settings.....	144
11	Start-up and operation.....	145
11.1	Safety	145
11.2	Commissioning.....	146
11.3	Switching on and off the barrier	146
11.4	Putting the barrier temporarily out of operation	147

12	Maintenance	149
12.1	Safety	149
12.2	Cleaning	150
12.3	Maintenance schedule.....	151
13	Malfunctions	153
13.1	Safety	153
13.2	Malfunction table – barrier malfunctions.....	154
13.3	Warning and interference messages on the display.....	157
13.3.1	Warning and interference messages – Logic control (control unit).....	157
13.3.2	Warning and interference messages – Motor GW	159
13.3.3	Warning and interference messages – detector.....	160
13.3.4	Warning and interference messages – All modules	160
13.4	Reset the barrier	161
13.5	Closing or opening the barrier boom in case of power failure	162
14	Repair	163
14.1	Safety	163
14.2	Spare parts	164
14.3	Replacing the barrier boom	164
15	Decommissioning, disassembly and disposal	165
16	EC-Declaration of conformity	167
17	Appendix.....	168
17.1	Wiring diagram.....	168
17.2	Menu setup	177
Index.....		181

General

1 General

1.1 Information regarding the operating instructions

These operating instructions provide crucial information on handling of MAGNETIC barriers MHTM™ MicroDrive Access XL and Access XXL. Pre-requisite for safe working is the observance of all specified safety notes and instructions.

In addition, the local accident prevention regulations valid at the barrier's area of application and general safety regulations have to be complied with.

Carefully read the operating instructions before starting any work! They are a product component and must be kept in direct proximity of the barrier, well accessible to the personnel at all times.

When passing the barrier on to third parties, the operating instructions must also be handed over.

Components from other suppliers may have their own safety regulations and instructions for use. These must also be observed.

Programme versions Control unit MGC and plug modules

These operating instructions are only valid as of the following programme versions. Software number (software #) and software version (SW version) are displayed in the menu "Module info".

Designation	Software #	SW version
Master Controller Standard	4915,1000	0.10
Motor Gateway Controller	4915,3000	0.10
Detector module 2-channel	4915,3001	0.10
Radio module 433 MHz	4915,3003	0.10
Ethernet Module	4915,3004	0.10

Table 1: Programme versions

1.2 Pictogram explanation

Warning notes

Warning notes are characterised by pictograms in these operating instructions. The warning notes are followed by signal words expressing the scale of the hazard.

It is absolutely essential to observe the notes and to proceed with caution in order to prevent accidents as well as bodily injuries and property damage.

⚠ DANGER!	
	<p>DANGER!</p> <p>... points to an immediately dangerous situation, which leads to death or severe injuries if it is not avoided.</p>

⚠ WARNING!	
	<p>WARNING!</p> <p>...points to a possibly dangerous situation that may lead to death or severe injuries if it is not avoided.</p>

⚠ CAUTION!	
	<p>CAUTION!</p> <p>... points to a potentially dangerous situation, which can lead to minor injuries if it is not avoided.</p>

NOTICE!	
	<p>NOTICE!</p> <p>... points to a potentially harmful situation, which can lead to property damage if it is not avoided.</p>

Hints and recommendations

	<p>NOTE!</p> <p>...highlights useful hints and recommendations as well as information for an efficient and trouble-free operation.</p>
---	---

General

1.3 Limitation of liability

All specifications and notes in these operating instructions were compiled with consideration to the valid standards and regulations, the state of the art as well as to our long-standing knowledge and experience.

The manufacturer is not liable for damages caused by:

- Non-observance of the operating instructions
- Improper use
- Deployment of non-instructed people
- Arbitrary modifications
- Technical changes
- Use of non-approved spare and wear parts.

The actual scope of supply may differ from the explanations and illustrations described in this manual in case of special designs, if additional order options are made use of, or due to latest technical changes.

1.4 Copyright protection

Surrendering the operating instructions to third parties without written permission of the manufacturer is not permitted.



NOTE!

Content details, texts, drawings, pictures and other illustrations are protected by copyright and are subject to industrial property rights. Any improper use shall be liable to prosecution.

Any type and form of duplication – also of extracts – as well as the exploitation and/or communication of the contents are not permitted without the manufacturer's written declaration of consent.

1.5 Scope of delivery

The scope of delivery comprises:

- 1 barrier housing
incl. drive unit and control
- 1 Barrier
- 2 Attachment profiles
- 2 Prohibition sign stickers
- Edge protection
- Options if applicable

Supplied documentation per barrier:

- These operating instructions.

1.6 Warranty

Subject to the condition that the operating instructions are observed, and that no inadmissible operations are carried out on the technical equipment, and that the installation has suffered no mechanical damage, MAGNETIC grants a warranty on all mechanical and electrical components of the extent as stated in its standard terms of sales and delivery or as contractually agreed in writing.

1.7 Disclaimer

MAGNETIC expressly disclaims all implied and statutory warranties, including but not limited to, the implied warranties of merchantability and fitness for a particular purpose with respect to the product and the statutory warranty of non-infringement of third party rights set forth in section 2312(3) of the uniform commercial code.

1.8 Customer service

Your vendor is available to you for technical information

For the address, see invoice, delivery note or the reverse of these instructions.



NOTE!

In order to enable fast handling note the data of the type plate such as type key, serial number, etc. before calling.

General

1.9 EC-Declarations of conformity

EC-Declarations of conformity (pursuant to EC Machinery Directive 2006/42/EC, Annex II) refer to page 167.

1.10 Environmental protection

NOTICE!	
	<p>Danger for the environment by improper disposal of components or the barrier!</p> <p>In case of improper disposal of components or the barrier, damage to the environment may result.</p> <p>Therefore:</p> <ul style="list-style-type: none">– Observe the valid environmental directives.– After appropriate disassembly the parts have to be recycled.– Separate recyclable fraction and feed to recycling.

2 Safety

2.1 Intended use of the barriers

The MAGNETIC MHTM™ MicroDrive barriers are exclusively intended for controlling access to and exit of certain road vehicles in or from certain areas.

The barrier is either controlled by a person in manual operating modes or by access control systems in automatic operating modes and monitored by induction loops and/or safety light barriers.

Electrical energy is used exclusively for operating the barrier. The barrier boom weight is balanced out by spring energy.

The barrier consists of a barrier housing with drive system and control, as well as the barrier boom.

2.1.1 Intended use for certain road vehicles

Certain road vehicles according to chapter 2.1 paragraph 1 need to have sufficiently large metal areas in the vehicle floor area to enable detection by induction loops.

Other or complementary safety facilities must be provided for road vehicles that cannot be detected by induction loops due to the metal area in the vehicle floor area being too small.

Additional safety installations must be provided for motorcycles.
→ Also see page 38, arrangement of "passenger car and motorcycle loops".

2.1.2 Barrier, pedestrian traffic impossible

In vehicle barriers where personal traffic is excluded and use by pedestrians is not intended.

The presence of persons and animals must be excluded by the operator. This shall apply for the following barrier types:

- Access XL
- Access XXL

2.1.3 Non-intended use

Control of pedestrian traffic as contrary to intended use.

The barriers must not be used at railway crossings.

The barriers are not approved for persons pedestrian traffic, bicycles or animals.

The barriers must not be used in explosive environments.

All uses not described as intended use are prohibited.

No accessories must be connected or installed if they are not specified expressly according to quantity and characteristics and approved by Magnetic Autocontrol.

WARNING!



Non-intended use is dangerous!

Every non-intended use can lead to dangerous situations.

Therefore:

- Only use barrier as intended.
- All specifications in these operating instructions have to be strictly complied with.

Any types of claims due to damage arising from improper use are excluded. The operator alone shall be responsible for any damage arising from improper use.

2.2 Operator's responsibility

The operator must comply with the statutory obligations regarding work safety.

In addition to the work safety notes in these operating instructions, the safety, accident prevention and environmental provisions applicable for the area the barrier is used in must be complied with.

In particular, the operator must:

- gather information on applicable work protection provisions.
- determine additional dangers in a risk assessment.
- implement the required method of operation of the barrier on site from the operating instructions.
- regularly verify throughout the barrier's time of use that the operating instructions drawn up by him comply with the current state of the regulations.
- adapt the operating instructions to any new provisions, standards and usage conditions - where required.
- clearly determine the responsibilities for installation, operation, maintenance and cleaning of the barrier.
- ensure that all employees that are working at or with the barrier have read and understood the operating instructions.
- Furthermore, the operator must train personnel regarding the use of the barrier at regular intervals and provide information on possible danger.

Furthermore, the operator is responsible for:

- keeping the barrier in perfect technical order and condition at all times.
- maintaining the barrier according to the maintenance intervals and performing the safety inspections as stipulated.
- checking all protective facilities for completeness and proper function at regular intervals.

The operator is also responsible that the danger area of the barrier boom cannot be accessed by any unauthorised persons, and in particular not by children, under any circumstances.



2.3 Changes and modifications

Changes, modifications and re-builds of the barrier or installation can cause unforeseen danger.

A written authorisation of the manufacturer is required before executing any technical changes and extensions on the barrier.

2.4 Specialists and operating personnel

2.4.1 Requirements

 WARNING!	
	<p>Risk of injury in case of inadequate qualification!</p> <p>Improper handling can lead to considerable bodily injuries and property damage.</p> <p>Therefore:</p> <ul style="list-style-type: none"> – Have any activities only carried out by the individuals designated for that purpose.

The operating instructions specify the following qualification requirements for the different fields of activity:

- **Instructed people**
have been instructed during instructions provided by the operator with regard to the work assigned to them and possible hazards arising from improper conduct.
- **Specialised staff**
are able, due to their technical training, knowledge and experience as well as their knowledge of the pertinent regulations are able to carry out work assigned to them independently and to recognise potential hazards.
- **Electricians**
are able, due to their technical training, knowledge and experiences as well as knowledge of the relevant standards and regulations, to execute tasks on electrical systems and to independently recognise possible hazards.
In Germany, the electricians must comply with the provisions of accident prevention regulation BGV A3 (e.g. master electrical fitter). Appropriate regulations apply in other countries. The regulations valid there must be observed.
- **MHTM™ MicroDrive service specialists**
comply with the requirements of the electricians named here. Additionally, these electricians are trained and authorised by MAGNETIC to perform special repair and service work at MHTM™ MicroDrive barriers.

It must be expected that only those people are deployed who carry out their work reliably. People, whose ability to respond is affected, e.g. by drugs, alcohol or medicines, must not be used.

Furthermore, the age and profession-specific regulations valid at the operating location must be observed when selecting personnel.

2.5 Personal protective equipment

It is necessary to wear personal protective equipment when dealing with the barrier so as to minimise health hazards.

Before carrying out any work, properly dress in the necessary protective equipment such as work clothes, protective gloves, safety shoes, helmet and wear during work.

2.6 Occupational safety and special dangers

The remaining risks resulting from the risk analysis are specified in the following section.

Observe the safety notes listed here and the warning notes mentioned in the other chapters of these instructions to reduce health hazards and to avoid dangerous situations.

2.6.1 Danger symbols on the MHTM™ MicroDrive barrier

The relevant dangerous areas on the barriers can be identified by the following pictograms:

Electric voltage

⚠ DANGER!	
	<p>Mortal danger by electric voltage!</p> <p>... indicates life threatening situations caused by electric voltage. Non-observance of the safety instructions causes severe injuries or death. Necessary work may only be carried out by electricians.</p> <p>This pictogram is fixed on the following component:</p> <ul style="list-style-type: none"> – Assembly plate in the barrier housing.

Danger of crushing

⚠ WARNING!	
	<p>Danger of crushing!</p> <p>... indicates the presence of components and items moving towards each other. Non-observance of the safety instructions can cause severe injuries.</p> <p>This pictogram is fixed on the following component:</p> <ul style="list-style-type: none"> – At the access points for the lever system on the front and rear of the top assembly plate. – At the access point for the flanged shaft on the front and rear of the top assembly plate.

Safety

Hot surfaces

⚠ CAUTION!	
	<p>Danger of burns!</p> <p>... indicates the presence of a hot surface. Non-observance of the safety instructions can lead to minor injuries.</p> <p>This pictogram is fixed on the following component:</p> <ul style="list-style-type: none"> – Motor in the barrier housing. – Heating (optional) in the barrier housing.

2.6.2 Hazard notes and occupational safety

For your own safety and for the protection of the barrier modules, the following information must be observed and complied with:

Electric voltage

⚠ DANGER!	
	<p>Mortal danger by electric voltage!</p> <p>Touching live parts can be lethal. Damage to the insulation or to individual components can be lethal.</p> <p>Therefore:</p> <ul style="list-style-type: none"> – Switch off the power supply immediately in case of damage to the insulation and arrange repair. – Only electricians may carry out work on the electrical system. – Switch off power supply and secure against reactivation before performing any work. Test for absence of voltage! – Never bypass or deactivate fuses. – When replacing fuses observe the correct amperage specification. – Keep moisture and dust away from live parts. Moisture or dust may cause a short circuit. If the electrical connection is established during precipitation, e.g. rain or snow, penetration of moisture must be prevented by suitable measures, such as a protective cover.

**Electric voltage –
missing safety installations**



⚠ DANGER!	
	<p>Mortal danger by electric voltage!</p> <p>The safety installations that are required according to regional and local regulations must be provided by the customer. Usually these are:</p> <ul style="list-style-type: none">– Residual current device (RCD)– Circuit-breaker– Lockable 2-pole main switch according to EN 60947-3.

**Thunderstorm, lightning,
electric voltage**



⚠ DANGER!	
	<p>Mortal danger from lightning and electrical voltage!</p> <p>If lightning strikes the barrier, contact to the barrier components and direct proximity to the barrier includes mortal danger.</p> <p>Therefore:</p> <ul style="list-style-type: none">– Never install the barrier housing and barrier boom during thunderstorms.– Protect yourself in buildings or vehicles.

Safety

Improper operation

 WARNING!	
	<p>Danger from improper operation of the barrier!</p> <p>Improper operation of the barrier can cause severe or lethal injuries!</p> <p>Therefore:</p> <ul style="list-style-type: none"> – The barrier closes automatically in certain programme modes. Passing of two vehicles within a single opening process must be prevented by the construction and appropriate signs or signals. – The barrier is intended for a single drive direction at the same time. The operator must prevent concurrent oncoming traffic by suitable measures, such as signs. – Only additions to the barrier casing or boom that are permitted by the manufacturer may be installed. – Keep barrier area free from objects. – Do not use the barrier boom as a lifting device. – Never climb over or crawl under boom. – Never sit on the barrier housing or climb over it. – Do not sit or have yourself lifted by the boom. – Never open or stop the boom manually.

Entering the danger area of the barrier

 WARNING!	
	<p>Danger from entering the danger area!</p> <p>The MAGNETIC MHTM™ MicroDrive barriers are intended exclusively for closing off passages for motor vehicles and trucks. For vehicles that cannot be detected by induction loops, additional safety measures must be provided. Entering the danger area can cause severe or lethal injuries!</p> <p>Therefore, the operator must take the following measures:</p> <ul style="list-style-type: none"> – Observing country-specific laws and regulations. – Presence of persons and animals must be excluded. – Marking the danger area by prohibition signs for persons, bicycles, etc. – If required, set up barriers such as fences and railings. – If required, set up separate passageway for persons and bicycles.

Closing boom

⚠ WARNING!	
	<p>Danger from closing boom!</p> <p>A closing boom may cause severe or lethal injury to persons, bicyclers, cabriolet drivers and motorcycle drivers!</p> <p>Therefore:</p> <ul style="list-style-type: none"> – Install safety installations, such as a MAGNETIC safety light barrier as surveillance device. The surveillance device must prevent the closing of the barrier in case a person or a vehicle is standing below the barrier. – Only use barrier booms approved of by MAGNETIC. – Assemble edge protection. – If the edge protection was damaged it must be replaced immediately or the barrier must be taken out of operation.

Improper transport



⚠ WARNING!	
	<p>Danger from improper transport of the barrier boom and housing!</p> <p>The weight of the barrier boom or housing can severely injure a person!</p> <p>Therefore:</p> <ul style="list-style-type: none"> – Have all transport work performed by specialists only. – Use lifting gear or forklift with a suitable pallet. – Use suitable lifting gear (loops, etc.) for lifting the barrier boom and barrier housing. The lifting gear must be designed for the respective weights. – Carrying and lifting the barrier boom and housing from the pallet should be done by at least two people.

Heavy weight



⚠ WARNING!	
	<p>Risk of injury when lifting heavy objects alone!</p> <p>The weight of heavy objects can severely injure a person!</p> <p>Therefore:</p> <ul style="list-style-type: none"> – Lifting and carrying the barrier boom and housing from the pallet should be done by a minimum of two people.

Safety



Falling components

 WARNING!	
	<p>Risk of injury from falling components!</p> <p>Calling components such as the barrier boom can cause severe injury!</p> <p>Therefore:</p> <ul style="list-style-type: none"> – Only place the barrier boom horizontally. – Only install the barrier boom when there is no or little wind. – Secure the barrier housing against tilting before assembly. – Install the barrier housing correctly.

Insufficient fixing

 WARNING!	
	<p>Risk of injury at insufficient fixing!</p> <p>Insufficient fixing of individual components such as barrier housing, barrier boom and additions permitted by the manufacturer can cause severe injury!</p> <p>Therefore:</p> <ul style="list-style-type: none"> – Only qualified and skilled personnel are allowed to assemble the barrier and the appropriate components. – Check the foundation anchors fit tightly before starting the barrier. – Check the firm fixing of all screws according to maintenance schedule.

Danger of crushing, lever system and flange shaft

 WARNING!	
	<p>Danger of crushing at opened barrier housing at the lever system and flange shaft!</p> <p>The lever system and the flange shaft in the barrier housing can cause serious crushing injuries!</p> <p>Therefore:</p> <ul style="list-style-type: none"> – Only qualified and skilled personnel are allowed work on the barrier housing and barrier boom. – Only work at the barrier housing when the power supply is turned off. – Assemble barrier housing without barrier boom. – For assembly of the barrier boom, strictly observe the descriptions in chapter 8. – Wear protective gloves if necessary.

**Danger of crushing,
barrier boom and flange**

⚠ WARNING!



Danger of crushing between barrier boom and barrier housing!

Moving parts may cause serious crushing injuries!

Therefore:

- Only qualified and skilled personnel are allowed work on the barrier housing and barrier boom.
- Only work at the barrier housing when the power supply is turned off.

Illegible signage

⚠ CAUTION!



Risk of injury by illegible symbols!

Labels and signs can become dirty or unrecognisable in the course of time.

Therefore:

- Always keep safety, warning and operating notes in a well readable condition.
- Immediately renew damaged or unrecognisable signs or labels.

Safety

2.7 Danger area

Danger of crushing and shearing, barrier boom

⚠ WARNING!	
	<p>Danger of crushing and shearing if the safety distance between the barrier boom and other objects is too low!</p> <p>A closing or opening barrier boom can cause severe injuries from crushing if the safety distance to other objects is too low!</p> <p>Therefore:</p> <ul style="list-style-type: none"> – Keep a safety distance of at least 500 mm between the barrier boom and other objects, such as walls, masonry or houses.

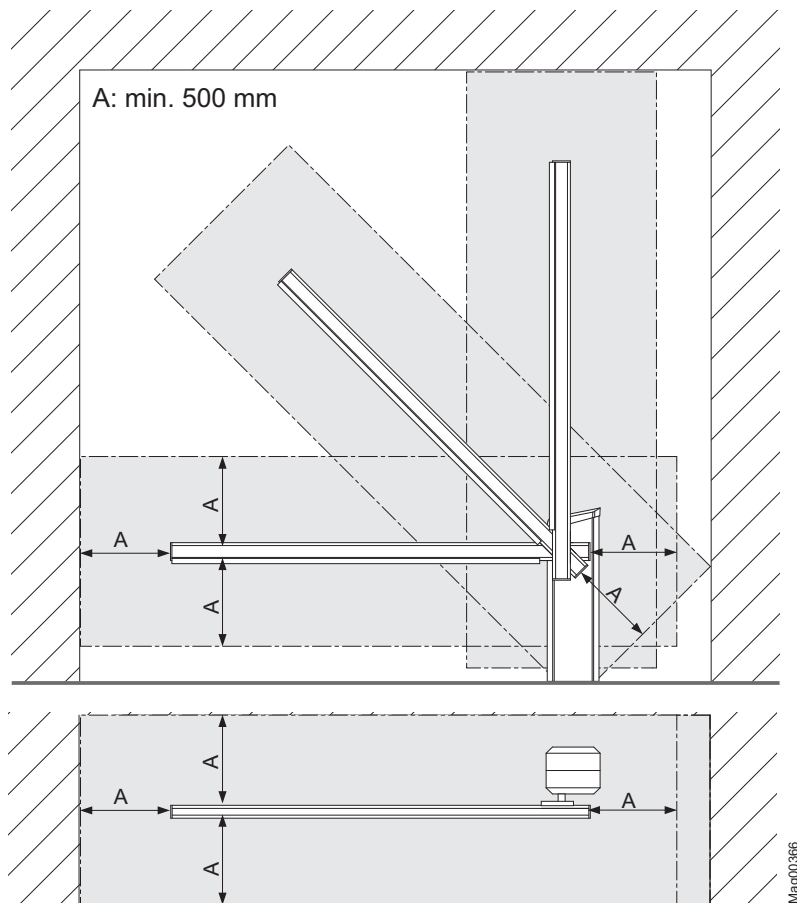

Fig. 1: Danger area

A Danger area of 500 mm

3 Identification

3.1 Type plate

The type plate is provided inside at the barrier housing, next to the hood attachment.

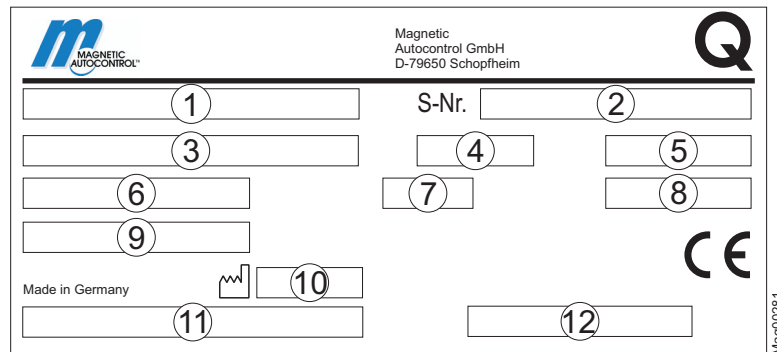

The diagram shows a type plate with the following fields and specifications:



- Top left:  MAGNETIC AUTOCONTROL™
- Top right: Magnetic Autocontrol GmbH, D-79650 Schopfheim
- Far right: 
- Field 1: Type code
- Field 2: S-Nr. (Serial number)
- Field 3: Power supply, Frequency
- Field 4: Current consumption
- Field 5: Power consumption
- Field 6: Operating time (Opening time/closing time)
- Field 7: Protection class
- Field 8: Duty cycle
- Field 9: Wind load classification (only for barrier where pedestrian traffic is possible)
- Field 10: Manufacturing year and month (with a small calendar icon)
- Field 11: Bar code for type code
- Field 12: Bar code for serial number
- Bottom left: Made in Germany
- Bottom right: 
- Vertical text on the right: Mag00281

Fig. 2: Type plate

- 1 Type code
- 2 Serial number
- 3 Power supply, Frequency
- 4 Current consumption
- 5 Power consumption
- 6 Operating time (Opening time/closing time)
- 7 Protection class
- 8 Duty cycle
- 9 Wind load classification
(only for barrier where pedestrian traffic is possible)
- 10 Manufacturing year and month
- 11 Bar code for type code
- 12 Bar code for serial number

Identification

3.2 Type code

													-	R	A	0	3	0	0	0
1	2	3	4	5	6	7	8	9	10	11	12	13	14	15	16	17	18	19	20	

Position	Description
1 – 12	Product group: ACCESS XL Magnetic.Access XL ACCESS XXL Magnetic.Access XXL
13	–
14	L = Left version R = Right version
15	A = Standard wide range 85 – 264 V AC / 47 – 63 Hz C = UL-version (US market)
16 – 18	Lane width Standard length: 060 = 6.0 metre 085 = 8.5 metre 100 = 10.0 metre (ACCESS XXL only)
19	Colours 0 = Top cover: IGP-DuraFace 581MA20000A00 (RAL 2000) Housing: IGP-DuraFace 622SA22770A00 (RAL2000) Doors: IGP-DuraFace 5803E 71319A10 (anthracite) 1 = Top cover: IGP-DuraFace 581ME71384A10 (grey aluminium) Housing: IGP-DuraFace 622SE71384A10 (grey aluminium) Doors: IGP-DuraFace 5803E 71319A10 (anthracite) 2 = Top cover: IGP-DuraFace 581ME90060A10 (white aluminium) Housing: IGP-DuraFace 622SE90060A10 (white aluminium) Doors: IGP-DuraFace 5803E 71319A10 (anthracite) X = Special coats of paint
20	0

4 Technical data

4.1 Access XL

4.1.1 Dimensions and weight

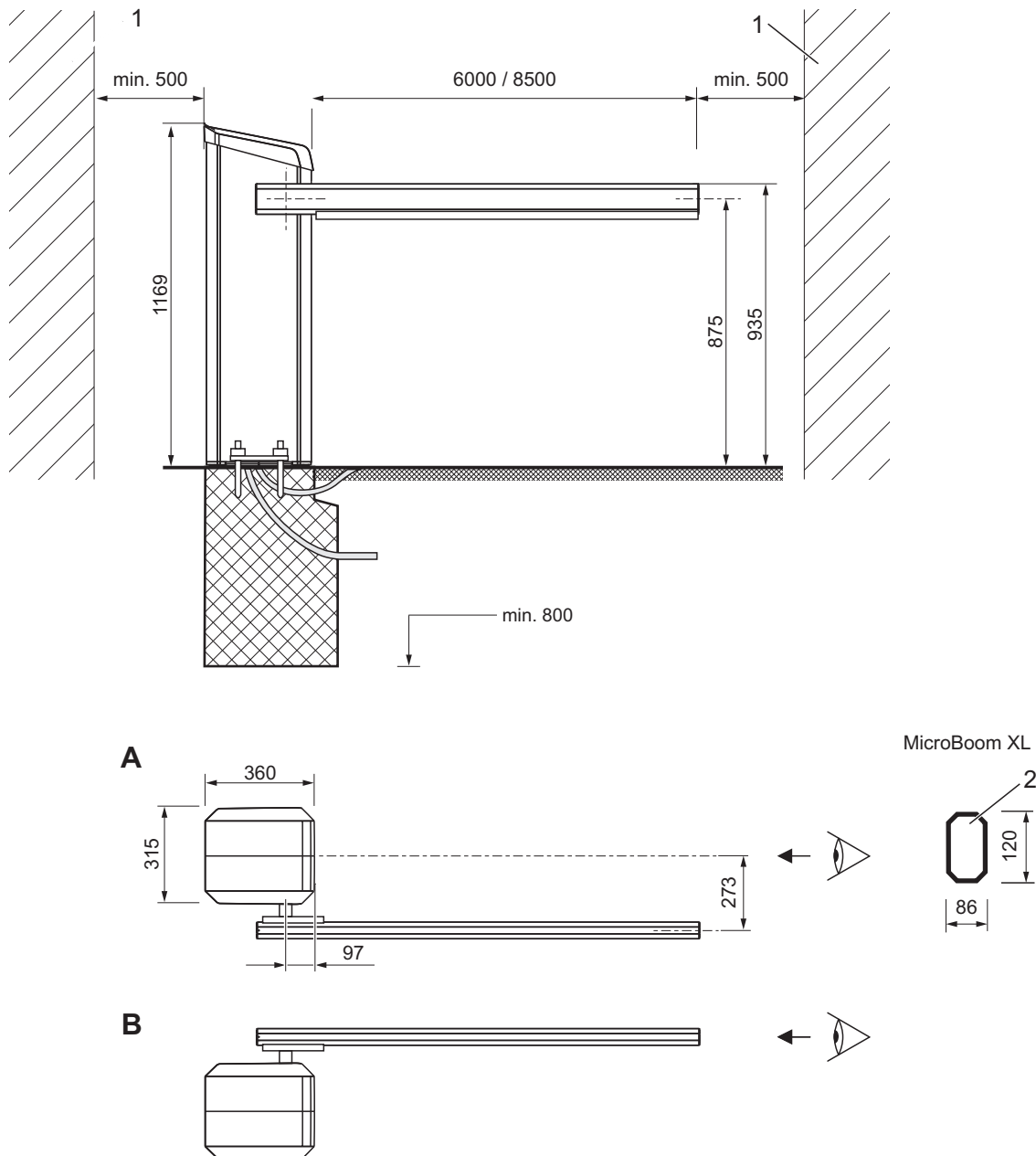

Fig. 3: Dimensions barrier system and barrier boom profile – "Access XL" series

- 1 Object such as wall, building, etc.
- 2 MicroBoom-XL (barrier boom) with octagon boom profile

- A Barrier, left version
- B Barrier, right version

Technical data

Designation	Unit	Access XL
Lane width ¹⁾	mm	6000 / 8500
Barrier housing (width x depth x height))	mm	→ See page 27, Fig. 3. (315 x 360 x 1169)
Barrier housing weight	kg	93

1) Starting at a lane width of 6 m, a pendulum support or nesting post is required.

Table 2: Dimensions and weight – "Access XL" series

4.1.2 Electrical connection

Designation	Unit	Access XL
Supply voltage	V AC	85 to 264
Frequency	Hz	50 / 60
Max. current consumption ¹⁾	A	0.3
Max. power consumption ¹⁾	W	35
Duty cycle	%	100

1) The values refer to power supply of 230 V AC / 50 Hz and without accessories.

Table 3: Electrical connection – "Access XL" series

4.1.3 Operating conditions

Designation	Unit	Access XL
Ambient temperature	°C	–30 to +50
Storage temperature	°C	–30 to +70
Relative humidity	%	max. 95 %, non-condensing
Wind force	Bft (Beaufort)	maximal 12
Protection class barrier housing	—	IP 54

Table 4: Operating conditions – "Access XL" series

4.1.4 Operating times

Designation	Unit	Access XL
Opening time/ closing time	s	6

Table 5: Operating times – "Access XL" series

4.2 Access XXL

4.2.1 Dimensions and weight

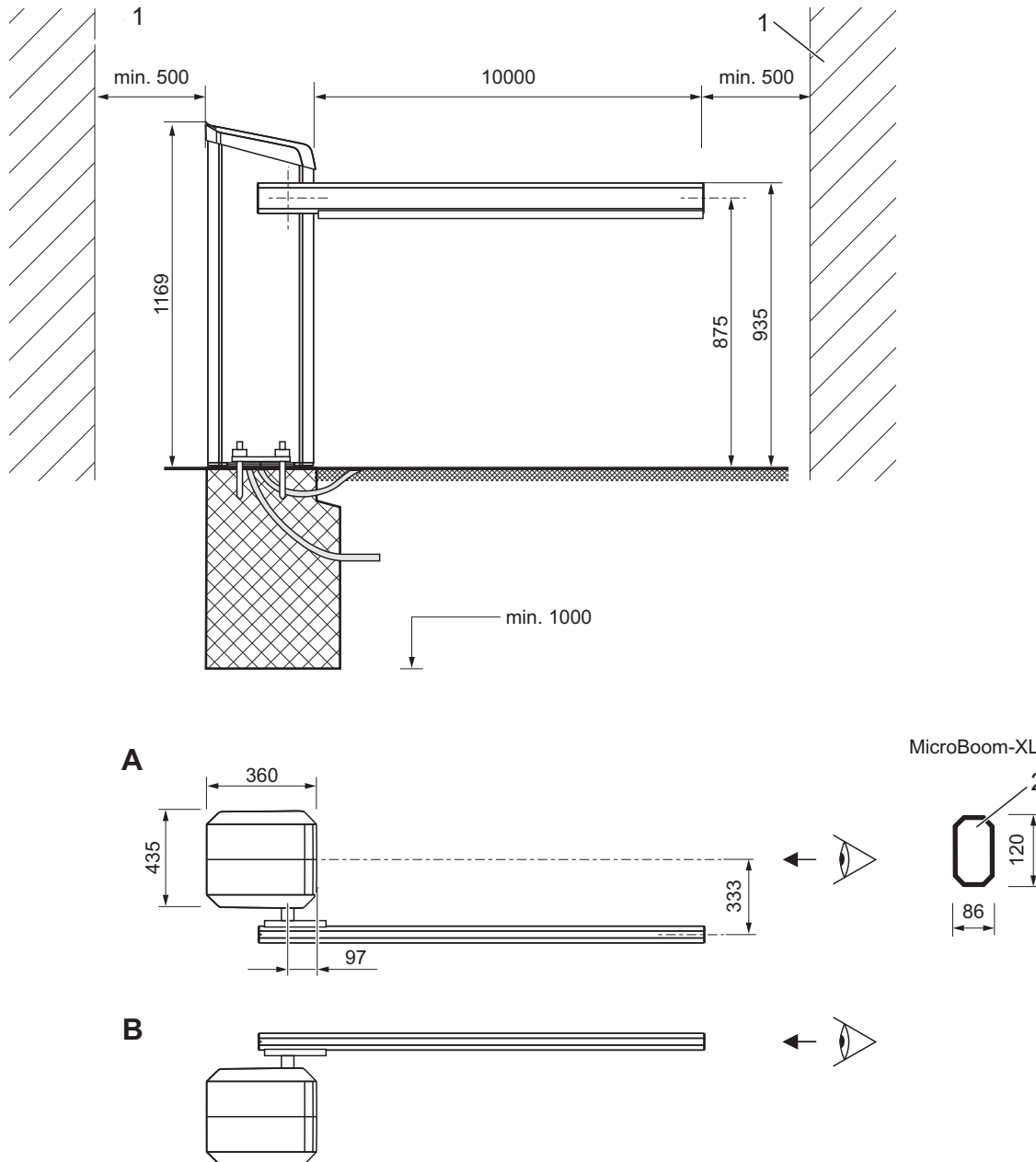

Fig. 4: Dimensions barrier system and barrier boom profile – "Access XXL" series

- 1 Object such as wall, building, etc.
- 2 MicroBoom-XL (barrier boom) with octagon boom profile

- A Barrier, left version
- B Barrier, right version

Technical data

Bezeichnung	Einheit	Access XXL
Lane width ¹⁾	mm	10000
Barrier housing (width x depth x height)	mm	→ See page 29, Fig. 4. (435 x 360 x 1169)
Barrier housing weight	kg	112

1) Starting at a lane width of 6 m, a pendulum support or nesting post is required.

Table 6: Dimensions and weight – "Access XXL" series

4.2.2 Electrical connection

Designation	Unit	Access XXL
Supply voltage	V AC	85 to 264
Frequency	Hz	50 / 60
Max. current consumption ¹⁾	A	0,3
Max. power consumption ¹⁾	W	35
Duty cycle	%	100

1) The values refer to power supply of 230 V AC and without accessories.

Table 7: Electrical connection – "Access XXL" series

4.2.3 Operating conditions

Bezeichnung	Einheit	Access XXL
Ambient temperature	°C	–30 to +50
Ambient temperature	°C	–30 to +70
Relative humidity	%	max. 95 %, non-condensing
Wind force	Bft (Beaufort)	maximal 10
Protection class barrier housing	—	IP 54

Table 8: Operating conditions – "Access XXL"

4.2.4 Operating times

Designation	Unit	Access XXL
Opening time/ closing time	s	8

Table 9: Operating times – "Access XXL"

4.3 Control unit

Designation		Unit	MGC (MAGNETIC Gate Controller)
Supply voltage		V DC	24
Current consumption		—	max. 1 A max. 300 mA + current consumption of the different plug-in modules
Power consumption		—	max 24 W. Max. 7.2 W + power consumption of the different plug-in modules
Control unit safety		—	1 A T
Output clamp X2	Output voltage	V DC	24
	Max. output current	mA	300
Digital inputs	Number	—	8
	Input voltage	V DC	24 ± 10 %
	Input current	—	< 10 mA per input
	Max. line length without overvoltage module ¹⁾	m	30
Digital outputs	Number	—	4 (open collector)
	Switching voltage	V DC	24 ± 10 %
	Max. switching current	mA	100
	Max. line length without overvoltage module ¹⁾	m	30
Output relay	Number	—	3 normally-open contacts and 3 change-over contacts, isolated
	Max. switching voltage	V AC / DC	30
	Switching current	mA	10 mA to 1 A
	Max. line length without overvoltage module ¹⁾	m	30
Display		—	Graphics display, 128 x 65 Pixel
Language display		—	Selectable: German, English, French, Spanish, Italian or Portuguese
Number of slots for plug-in modules		—	5

1) For line lengths exceeding 30 m, overvoltage modules must be installed in front of the terminal clamps.

Table 10: Control unit

Technical data

4.4 Plug-in module "Detector A–B"

Designation	Unit	Plug-in module "Detector A–B"
Current consumption	mA	50
Number of loop detectors	–	2 (A and B)
Inductance range	μH	70 to 500
Number of induction loop sensitivity levels	–	10 levels
Response sensitivity induction loop	%	Selectable: 0.01 to 2.0

Table 11: Plug-in module "Detector A–B"

4.5 Plug-in module "Radio"

Designation	Unit	Plug-in module "Radio"
Current consumption	mA	20
Frequency hand transmitter	MHz	433
HF modulation	–	FM/AM (depending on region)

Table 12: Plug-in module "Radio"

5 Design and function

5.1 Design

5.1.1 Access and Parking

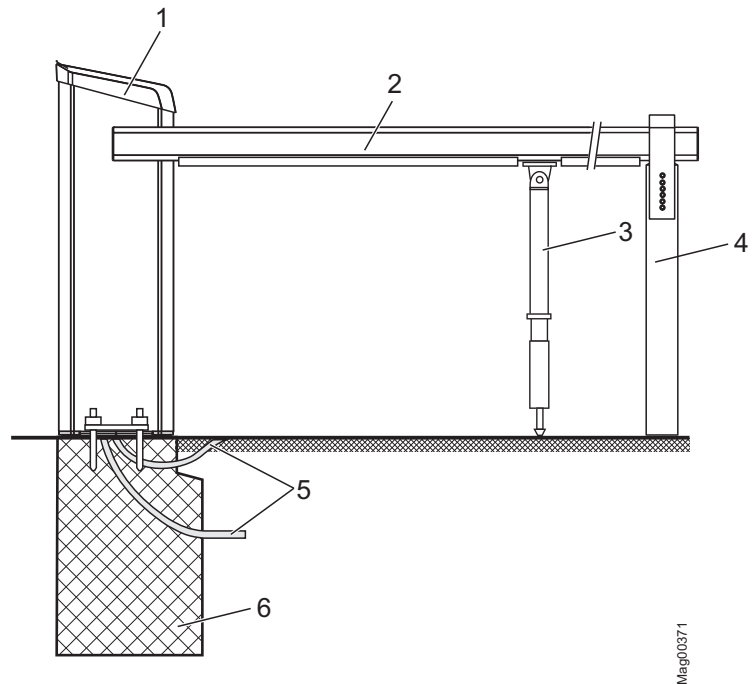

Fig. 5: Barrier system design Series "Access"

- 1 Barrier housing
- 2 MicroBoom-XL (barrier boom)
- 3 Pendulum support from 3.5 m barrier boom length (accessory)
- 4 Nesting post (accessory)
- 5 Empty conduits for mains cable, control lines and induction loop
- 6 Concrete foundation with reinforcement

Design and function

5.2 Function

The barrier consists of a barrier housing with drive system and a barrier boom.

The drive system consists of an electric motor, control unit, and the lever system. The lever system locks the barrier boom in both end positions. In case of power outage, the barrier boom can easily be moved by hand. Integrated balancing springs in the lever system balance out the boom weight exactly. These balancing springs are pre-set in the factory.

Sensors integrated in the motor supply exact data on every correct position of the barrier boom and thus serve the control unit to control the best acceleration and deceleration.

Safety facilities like induction loops or safety light barriers must be installed on site in all cases. The safety installations must ensure that the barrier closes only after the vehicle has passed through. Safety installations, such as induction loops can be purchased from MAGNETIC. The safety light barriers must be MAGNETIC ones.

6 Transport and storage

6.1 Safety notes for transport

Improper transport

⚠ WARNING!	
	<p>Danger from improper transport of the barrier boom and housing!</p> <p>The weight of the barrier boom or housing can severely injure a person!</p> <p>Therefore:</p> <ul style="list-style-type: none"> – Have all transport work performed by specialists only. – Use lifting gear or forklift with a suitable pallet. – Use suitable lifting gear (loops, etc.) for lifting the barrier boom and barrier housing. The lifting gear must be designed for the respective weights. – Lifting and carrying the barrier boom and housing from the pallet should be done by a minimum of two people.

Heavy weight

⚠ WARNING!	
	<p>Risk of injury when lifting heavy objects alone!</p> <p>The weight of heavy objects can severely injure a person!</p> <p>Therefore:</p> <ul style="list-style-type: none"> – Lifting and carrying the barrier boom and housing from the pallet should be done by a minimum of two people.

Transport and storage

Improper transport

NOTICE!	
	<p>The barrier system can be damaged by improper transport!</p> <p>Substantial material damages can result from improper transport.</p> <p>Therefore:</p> <ul style="list-style-type: none"> – Have all transport work performed by specialists only. – When unloading the packages and during in-plant transportation always proceed with greatest care and caution. – Observe the symbols on the packaging. – Observe the dimensions of the barrier system. – Loading, unloading as well as moving the barrier system must take place with greatest care. – Only remove packaging directly before assembly.

Personal protective equipment

The following must be worn during all transport work:

- Work clothes
- Protective gloves
- Safety shoes
- Protective helmet.

6.2 Transport inspection

Immediately check the delivery after receipt for completeness and transport damages.

Proceed as follows in the case of outwardly recognisable transport damage:

- Do not accept the delivery or only under reserve.
- Note the extent of damage on the transport documents or on the delivery note of the forwarder.
- Lodge complaint.



NOTE!

Lodge a complaint for each defect, as soon as it is recognised. Compensation claims can only be submitted within the valid complaint periods.

6.3 Transport

Barrier housing and barrier boom are delivered separately.

The lifting gear must be designed for the weight of the barrier housing and barrier boom.

For transport barrier modules refer to the safety notes on page 35, chapter 6.1.

For future transports:

- Secure loose cables.
- Secure against vibrations.
- Securely fasten the barrier housing and barrier boom prior to transport (e.g. screw it onto a pallet).
- Transport and put down barrier housing and barrier boom with a forklift and lift with suitable lifting gear.

6.4 Storage

Store the barrier or packages under the following conditions:

- Do not store outdoors.
- Store dry and dust free.
- Do not expose to aggressive media.
- Protect against solar irradiation.
- Avoid mechanical vibrations.
- Storage temperature: -30 to +70 °C
- Relative humidity: max. 95 %, non-condensing
- Check the general condition of all components and packaging regularly, if they are stored for longer periods than 3 months.

Design notes for induction loops

7 Design notes for induction loops

→ For assembly and inspection, see page 52, chapter 8.4.

Please observe following points when dimensioning the induction loops:

- Induction loops respond only to metal. The mass is thereby not important, but the size of the loop's surface, which will be covered by the metal part is.
- The induction loops must not respond to persons or objects with a small metal portion like a bicycle for instance.
- Motorcycles can be detected with appropriately installed induction loops. However, the induction loops are not a sufficient safety installation for motorcycles. Additional safety equipment, such as light barriers, light curtains etc. must be installed.
- Safety loops must secure the danger area underneath the barrier boom throughout the entire length.
- Opening loops must be installed right in front of the safety loop. The maximum distance between safety loop and opening loop must be not greater than max. 1.0 m.

Arrangement passenger car loops – standard

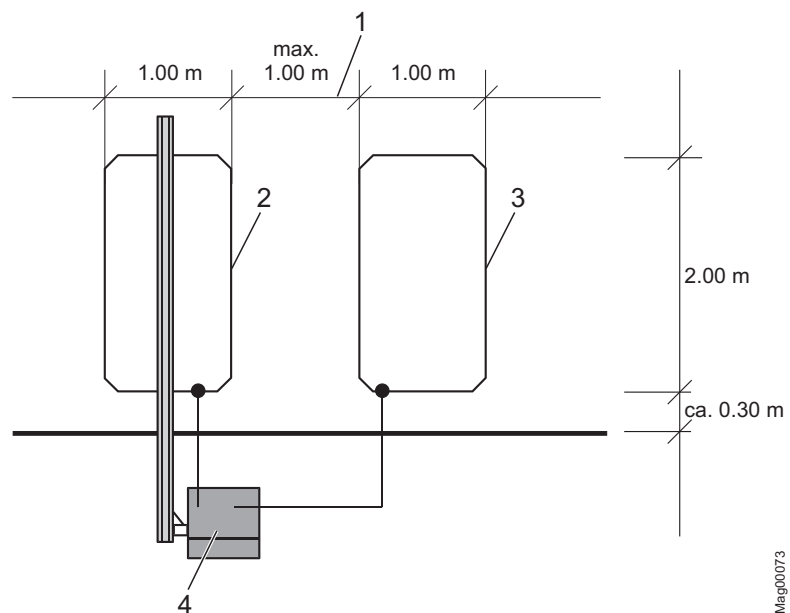
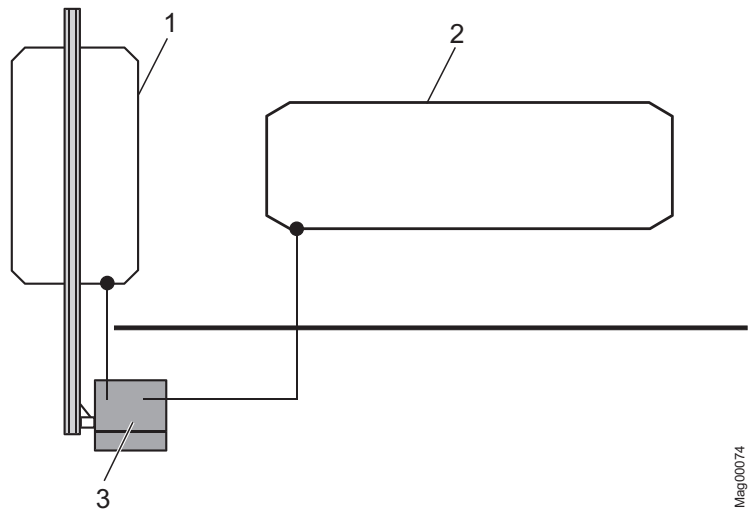

Fig. 6: Passenger car loop

- 1 Maximum distance between opening loop and safety loop
- 2 Safety loop
- 3 Opening loop
- 4 Barrier

Arrangement passenger car loops – passage with long opening loop

Mag00074

Fig. 7: Passenger car loops – passage with long opening time

- 1 Safety loop
- 2 Opening loop
- 3 Barrier

Due to a long opening loop vehicles can drive through without needing to stop.

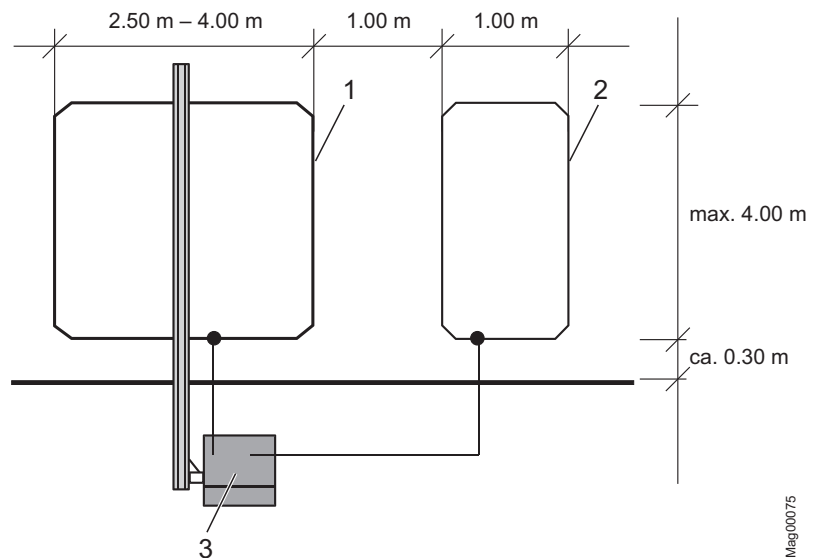
Arrangement of lorry loops

Mag00075

Fig. 8: Lorry loops

- 1 Safety loop
- 2 Opening loop
- 3 Barrier

For lorry passages the safety loop in the direction of travel must be at least 2.5 m long.

Design notes for induction loops

Arrangement of lorry/ passenger car loops

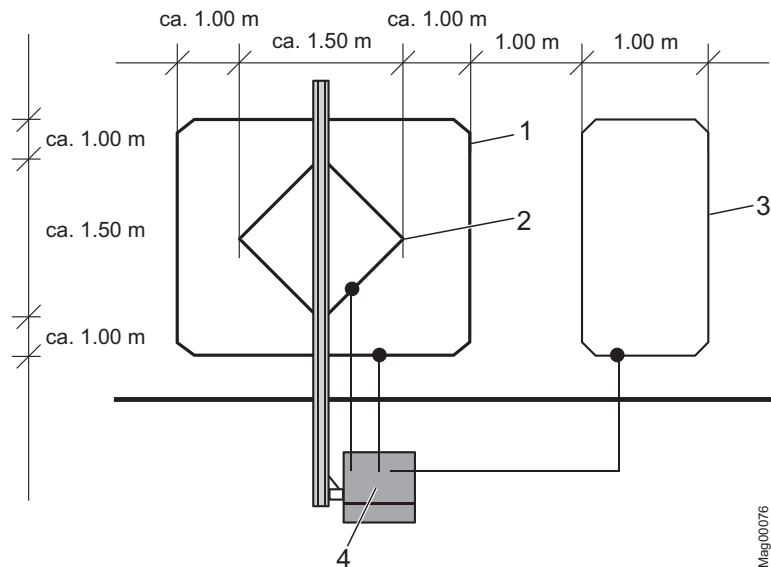

Fig. 9: Lorry/passenger car loops

- 1 Safety loop lorry (inductance "L1")
- 2 Safety loop passenger car (inductance "L2")
- 3 Opening loop lorry and passenger car
- 4 Barrier

Observe overall inductance " L_{total} ". For calculation, see below.

For combined lorry/passenger car loops following points must be additionally observed:

- The winding direction of the inner safety loop for passenger cars must be identical to the outer safety loop for lorries. Meaning, the sensitivity in the middle between outer and inner loop is then at its maximum.
- Outer and inner loop can be both connected with one detector channel, as the case may be.
- The overall inductance determines, whether the lorry and the passenger car loop have to be implemented as series or as parallel circuit. Always lead both feed lines into the barrier housing. The overall inductance must be between 70 and 500 μH .

Calculation of the overall inductance for series circuits

$$L_{total} = L1 + L2$$

Calculation of the overall inductance for parallel circuits

$$L_{total} = \frac{L1 \cdot L2}{L1 + L2}$$

Arrangement of passenger car and motorcycle loops

Fig. 10: Passenger car and motorcycle loops

- 1 Safety loop passenger car
- 2 Opening loop passenger car
- 3 Safety loop motorcycle
- 4 Opening loop motorcycle
- 5 Marked motorcycle track
- 6 Barrier

For passenger car loops combined with motorcycle loops following points must be additionally observed:

- Motorcycles can be detected with appropriately installed induction loops. However, the induction loops are not a sufficient safety installation for motorcycles. Additional safety equipment, such as light barriers, light curtains etc. must be installed.
- Use trapezium or slanted rectangular loops for passenger car loops combined with motorcycle loops. The angle to the direction of travel should preferably be 45°.
- Mark the motorcycle track clearly.
- The motorcycle track must consist of at least 6 windings.
- The winding direction of the passenger car loop and the motorcycle loop must be identical.

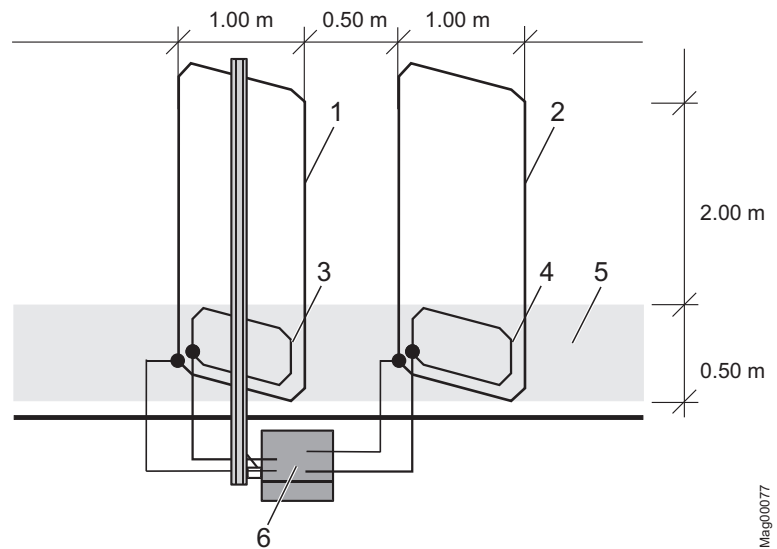

Assembly and installation

8 Assembly and installation



8.1 Safety

→ See also safety notes on page 17, chapter 2.6 "Occupational safety and special dangers".

General

 WARNING!	
	<p>Danger by inappropriate installation! Inappropriate installation can cause severe injuries! Therefore:</p> <ul style="list-style-type: none"> – Only specialists or electricians must perform any assembly and installation tasks. – Prior to work, ensure that there is sufficient assembly space. – Pay attention to tidiness and cleanness at the assembly site! Loosely stacked or lying around components and tools are accident sources. – Comply with specifications for foundations and reinforcement. – Ensure correct arrangement and fit on all assemblies and components. – Install the indicated fastening elements correctly.

Danger of crushing and shearing, barrier boom

 WARNING!	
	<p>Danger of crushing and shearing if the safety distance between the barrier boom and other objects is too low! A closing or opening barrier boom can cause severe injuries from crushing if the safety distance to other objects is too low! Therefore:</p> <ul style="list-style-type: none"> – Keep a safety distance of at least 500 mm between the barrier boom and other objects, such as walls, masonry or houses. → See page 24, chapter 2.7. – Assemble and install barrier system according to Fig. 11.

Personal protective equipment

The following must be worn during all assembly and installation work:

- Work clothes
- Protective gloves
- Safety shoes
- Protective helmet.

8.2 Required steps

The following steps are to be completed prior to assembly and installation:

- Laying the foundation with reinforcement for the barrier and install empty conduits.
- Set up foundation for nesting post or light barrier post and empty conduits.
- Installing induction loops.

The following procedures have to be observed during assembly and installation:

- Unpack barrier and accessories.
- Mount barrier housing on the foundation.
- Mount nesting post or light barrier post on the foundation.
- Mount safety light barrier.
- Assemble barrier boom (from 6 metre).
- Mount barrier boom.
- Mount edge protection.
- Adjust balancing springs.
- Align barrier housing and nesting post or light barrier post.
- Set nesting post height.
- Assemble and install signalling device.
- Arrange electrical connections.
→ See page 84, chapter 9.3.

Assembly and installation

8.3 Foundation and empty conduits

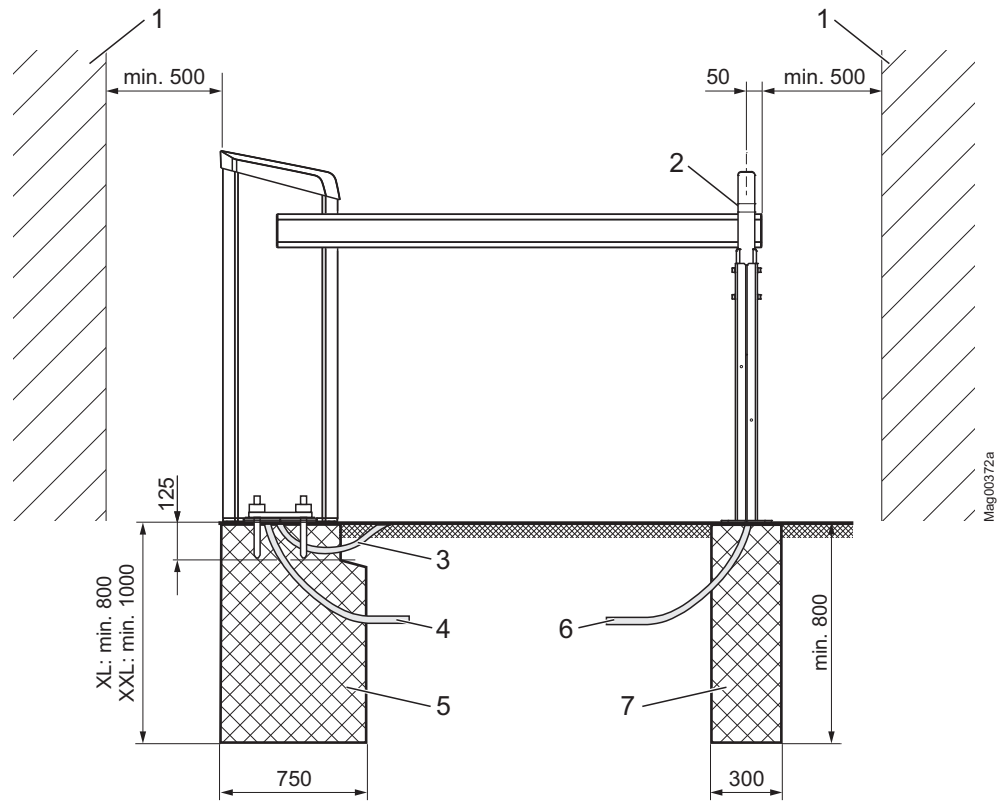

Fig. 11: Assembly boom system

- 1 Object like wall, building, etc.
Keep a safety distance of at least 500 mm between the barrier boom and other objects, such as walls, masonry or houses
- 2 Posts, e.g. nesting posts, place post centre at a distance of 50 mm to the barrier boom tip
- 3 Empty conduit for induction loop connection
- 4 One empty conduit each for mains cable and control lines
- 5 Foundation with reinforcement grid for barrier housing
- 6 Optional: Empty conduit for safety light barriers, connection line receiver
- 7 Optional: Foundation for nesting post or light barrier post, nesting post displayed here
Starting at a lane width of 6 m, a pendulum support or nesting post is required.

8.3.1 Foundation and empty conduits for the barrier Access XL

Assembly site

The assembly site must meet the following requirements:

- The barrier must not be put up where there is a danger of flooding.
- Keep a safety distance of at least 500 mm between the tip of the barrier boom and other objects, such as walls, masonry or houses. → See page 44, Fig. 11.

Foundation and reinforcement

The foundation must meet the following requirements:

→ See page 44, Fig. 11 and page 46, Fig. 13.

- have sufficient load-carrying capacity.
(concrete foundations: C35/45 XD3 XF2)
- Water cement value: 0.5
- Foundation depth: at least 800 mm, frost-protected foundation depth to be adjusted to the local situation.
- Foundation section: 750 mm x 750 mm
- Reinforcing grid as shown in figure Fig. 13.

Empty conduits

The empty conduits must meet the following requirements:

→ See page 46, Fig. 12.

- Separate empty conduits for mains cable and control line
Diameter: 29 mm each
- Optional empty conduit for induction loop.
Diameter: 29 mm each
- Conduits have to be planned to a sufficient length.



NOTE!

To provide a trouble-free operation use separate conduits for control lines and mains cables.

Assembly and installation

Laying the foundation, installing empty conduits

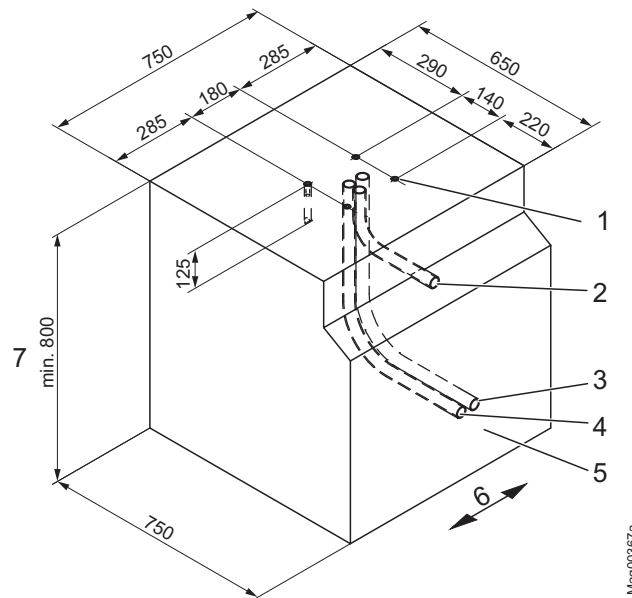

Fig. 12: Foundation plan Access XL

- 1 Foundation anchor (4 pcs.)
- 2 Optional when using loop connection; empty conduit for loop connection, diameter: 29 mm
- 3 Empty conduit for induction loop, diameter: 29 mm
- 4 Empty conduit for control lines, diameter: 29 mm
- 5 Concrete foundations (C35/45 XD3 XF2)
- 6 Carriageway
- 7 Foundation depth: at least 800 mm, frost-protected foundation depth to be adjusted to the local situation.

1. Dig foundation hole pursuant to Fig. 11 and Fig. 12.

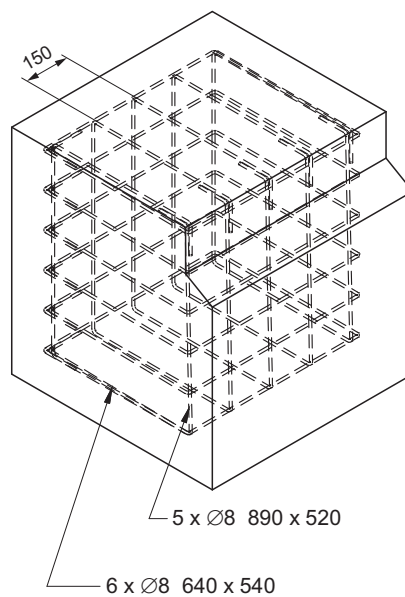

Fig. 13: Reinforcement grid Access XL

2. Place reinforcement grid pursuant to Fig. 13 in the foundation hole.
3. Place empty conduits pursuant to Fig. 12 in the foundation hole.
4. Close empty conduits to prevent water from entering.
5. Fill concrete foundation pursuant to Fig. 12.
6. Create flat line in the base area. The following requirements must be fulfilled:
 - Level and horizontal.
 - Surface deviation: max. 1 mm/m²
7. Let concrete cure.
8. Apply moisture protection agent to concrete surface.

**NOTE!**

We recommend applying moisture protection either in the form of sealing sludges such as 1100 Hansit or ready-made solution such as Sikagard® 703 W or deepdry® to the concrete surface before housing assembly. Moisture protection prevents entering of moisture into the housing from the concrete floor.

8.3.2 Foundation and empty conduits for the barrier Access XXL

Assembly site

The assembly site must meet the following requirements:

- The barrier must not be put up where there is a danger of flooding.
- Keep a safety distance of at least 500 mm between the tip of the barrier boom and other objects, such as walls, masonry or houses. → See page 44, Fig. 11.

Foundation and reinforcement

The foundation must meet the following requirements:

→ See page 44, Fig. 11 and page 46, Fig. 13.

- have sufficient load-carrying capacity.
(concrete foundations: C35/45 XD3 XF2)
- Water cement value: 0.5
- Foundation depth: at least 1000 mm, frost-protected foundation depth to be adjusted to the local situation.
- Foundation section: 750 mm x 750 mm
- Reinforcing grid as shown in figure Fig. 13.

Assembly and installation

Empty conduits

The empty conduits must meet the following requirements:

→ See page 46, Fig. 12.

- Separate empty conduits for mains cable and control line
Diameter: 29 mm each
- Optional empty conduit for induction loop.
Diameter: 29 mm each
- Conduits have to be planned to a sufficient length.



NOTE!

To provide a trouble-free operation use separate conduits for control lines and mains cables.

Laying the foundation, installing empty conduits

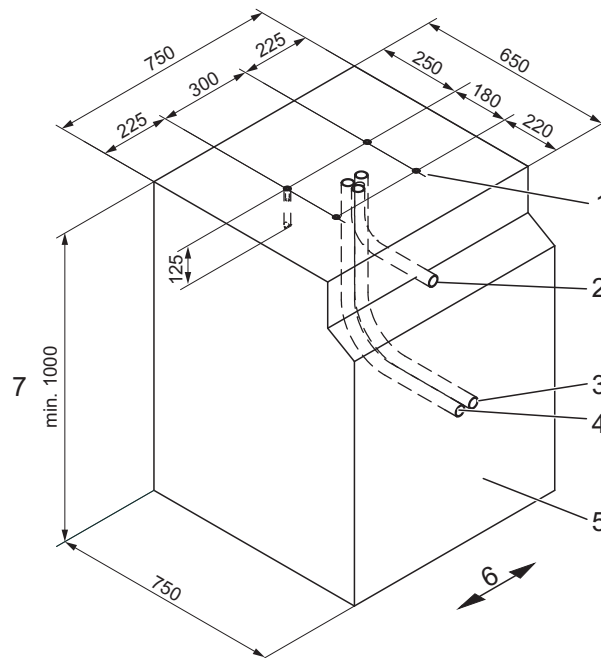

Mag00369a

Fig. 14: Foundation plan Access XXL

- 1 Foundation anchor (4 pcs.)
- 2 Optional when using loop connection;
empty conduit for loop connection, diameter: 29 mm
- 3 Empty conduit for induction loop, diameter: 29 mm
- 4 Empty conduit for control lines, diameter: 29 mm
- 5 Concrete foundations (C35/45 XD3 XF2)
- 6 Carriageway
- 7 Foundation depth: at least 800 mm, frost-protected
foundation depth to be adjusted to the local situation.

1. Dig foundation hole pursuant to Fig. 11 and Fig. 12.

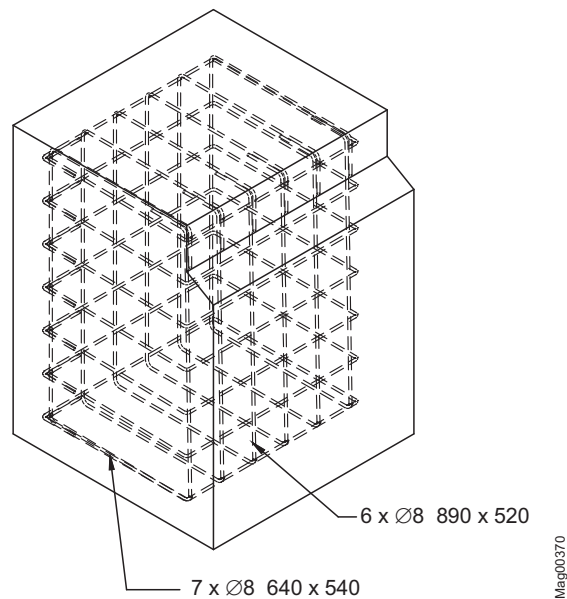

Fig. 15: Reinforcement grid Access XXL

2. Place reinforcement grid pursuant to Fig. 13 in the foundation hole.
3. Place empty conduits pursuant to Fig. 12 in the foundation hole.
4. Close empty conduits to prevent water from entering.
5. Fill concrete foundation pursuant to Fig. 12.
6. Create flat line in the base area. The following requirements must be fulfilled:
 - Level and horizontal.
 - Surface deviation: max. 1 mm/m²
7. Let concrete cure.
8. Apply moisture protection agent to concrete surface.



NOTE!

We recommend applying moisture protection either in the form of sealing sludges such as 1100 Hansit or ready-made solution such as Sikagard® 703 W or deepdry® to the concrete surface before housing assembly. Moisture protection prevents entering of moisture into the housing from the concrete floor.

Assembly and installation

8.3.3 Foundation and empty conduits for nesting post or light barrier post

Danger of crushing

⚠ CAUTION!	
	<p>Crushing danger between the fork at the nesting post and the barrier boom!</p> <p>Fingers and hands can be crushed when the barrier boom runs into the nesting post when closing.</p> <p>Therefore:</p> <ul style="list-style-type: none"> – Switch off power supply during assembly. – Do not hold on to fork from the inside. Wear safety gloves if required.

Dimensions

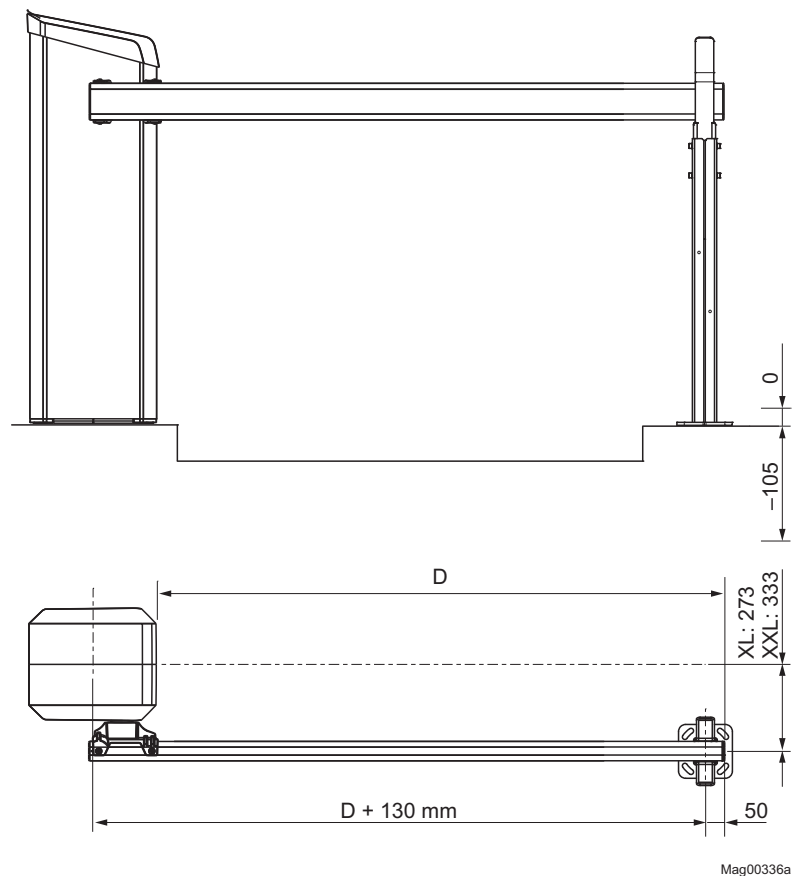

Fig. 16: Dimensions barrier casing – post

Assembly site

- The nesting post and light barrier post must not be put up where there is a danger of flooding.
- Place post centre at a distance of 50 mm from the barrier boom tip. → See page 50, Fig. 16.

Foundation

The foundation must meet the following requirements:

→ See page 44, Fig. 11 and page 51, Fig. 16.

- Have sufficient load-carrying capacity.
(concrete foundations: C35/45 XD3 XF2)
- Water cement value: 0.5
- Foundation depth: at least 800 mm, frost-protected
foundation depth to be adjusted to the local situation.
- Foundation section: 300 mm x 300 mm

Empty conduit

If the barrier system is equipped with a light barrier, an empty conduit must be installed for the transmitter connection line. Conduits have to be planned to a sufficient length.

Laying the foundation, Installing empty conduits

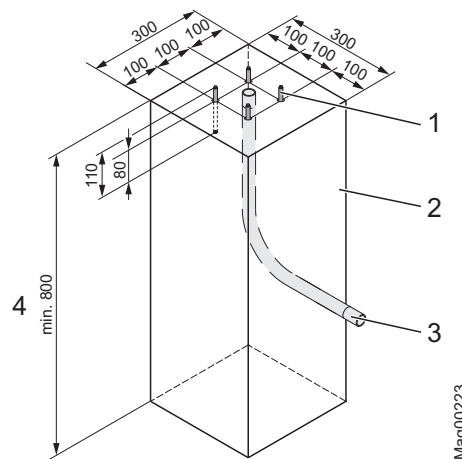

Fig. 17: Foundation plan for nesting post and light barrier post

- 1 Foundation anchor (4 pcs.)
 - 2 Concrete foundations (C35/45 XD3 XF2)
 - 3 Optional for light barriers:
Empty conduit for transmitter connection line
 - 4 Foundation depth: at least 800 mm, frost-protected
foundation depth to be adjusted to the local situation.
1. Dig foundation hole pursuant to and Fig. 17.
 2. Place empty conduit pursuant to Fig. 17 in the foundation hole.
 3. Close empty conduit to prevent water from entering.
 4. Fill concrete foundation pursuant to Fig. 17.
 5. Create flat line in the base area. The following requirements must be fulfilled:
 - Level and horizontal.
 - Surface deviation: max. 1 mm/m²
 6. Let concrete cure.

Assembly and installation

8.4 Assembly and installation of induction loops

Depending on the application safety installations must be installed on site. Induction loops, light barriers, etc. can be used as safety installations.

The safety installations must ensure that the barrier closes only after the vehicle has passed through. Safety installations, such as induction loops can be purchased from MAGNETIC.

8.4.1 Directions for the assembly and installation of induction loops

On barriers with an automatic closing function induction loops are used for the detection of vehicles. The loop underneath the barrier boom always serves as monitor and closing loop. Meaning, as long as a vehicle is standing on the loop, the barrier stays open. Only after the vehicle has left the loop will the barrier be closed.

Example

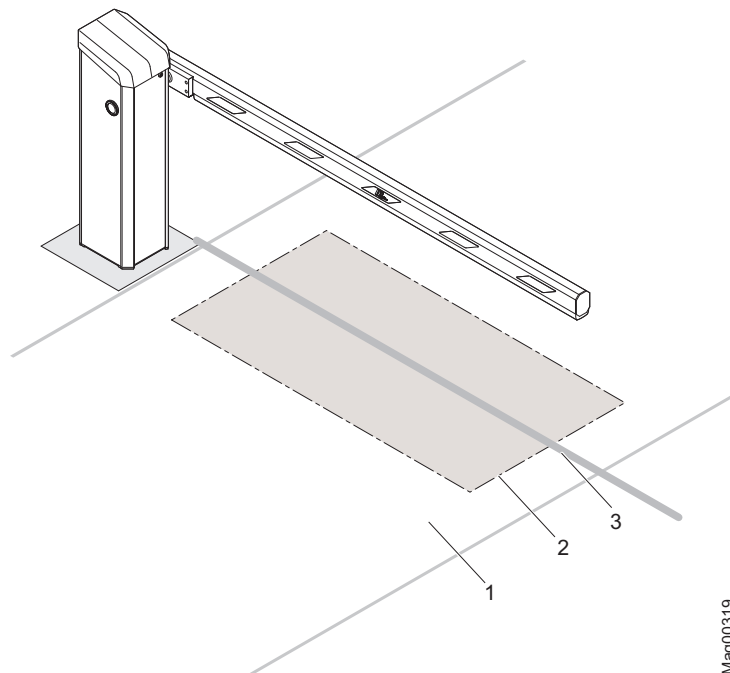

Fig. 18: Arrangement example of an induction loop for passenger car operation

- 1 Carriageway
- 2 Induction loop
- 3 Projection of the barrier boom onto the subsurface with a standard installation of the loop

→ The induction loop setup depends on the application case. For other application cases, refer to page 38, chapter 7.

Please observe following points when installing the induction loop:

Loop geometry and clearances

- Install the loop symmetrically to the barrier boom. Please make sure that the barrier boom is attached to the side of the barrier housing.
→ Refer from page 27, Fig. 3 onwards.
- The clearance of the safety loop for passenger cars in front of, and behind the barrier boom must be at least 500 mm. The safety loop for lorries must be dimensioned larger.
- The distance of the induction loop from the roadside should be about 300 to 500 mm.
- Install opening loops right in front of the safety loop. The clearance between opening loop and safety loop must be not greater than 1 m for lorries and passenger cars, and 0.5 m for motorcycles.
- If there are iron reinforcements, ramp heating etc. in the carriageway, the induction loop must have a clearance of at least 50 mm from those. Metals in the proximity of the induction loop affect the response sensitivity.
- Avoid direct contact of induction loops with reinforcement and ramp heating.
- Install induction loops with sufficient clearance from sliding gates, roller grilles etc.

Installation and ground conditions

- Please make sure when moulding or installing that the loop can not move anymore once it is in operation. Any geometric alteration will act as inductance change, which will set the detector to an error state.
- Brittle road surfaces, loose pavements, gravel paths etc. are not suited for the application of induction loops.

Feed line

- The feed line to the loop must not exceed 15 m.
- The loop connection cable must protrude about 1.5 m from the foundation.
- Shorten the feed line to the loop to the proper length. The feed line must by no means be coiled.
- The feed line must be twisted up to right in front of the terminals of the loop detector with approx. 20 twists per metre.

Assembly and installation

8.4.2 Induction loops

The induction loops are available as ready assembled cables in various lengths (Type KAS 1 to 5) from MAGNETIC.

Alternatively a loop can be manufactured from single wire. The following requirements must be fulfilled:

- Wire cross section: 0.75 to 1.5 mm²
- Inductance of the loop: 70 to 500 μH. This is equivalent to a loop with 3 to 6 windings.
- When using hot pouring compounds, such as bitumen temperature resistant loop cables/strands must be used.

8.4.3 Testing induction loops

To verify the contact resistance, insulation resistance, and inductance of the loop these properties must be measured after installation:

- Contact resistance: 0.8 to 2.0 ohms
- Insulation resistance to earth: > 1 Mohm.
- Inductance of the loop: 70 to 500 μH

If the values are not within the specified ranges, the loop is defective.

8.4.4 Installing induction loops in bitumen, asphalt, or concrete

1. Cut a 50 mm deep groove into the surface or asphalt using a cutting disc. The groove must be equally deep at every point. According to Fig. 14 the corners of the groove must be cut in a 45° angle.

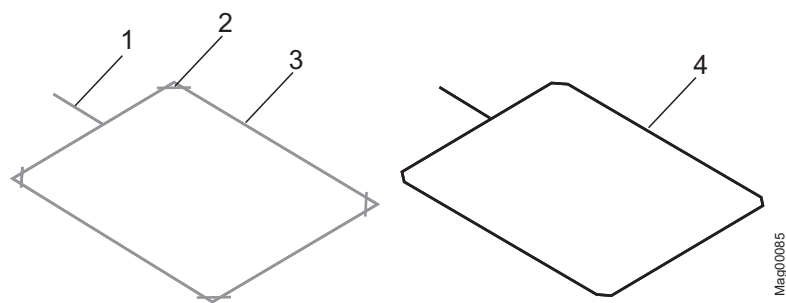

Fig. 19: Installing induction loop in bitumen, asphalt, or concrete

- 1 Groove for induction loop feed line
- 2 Corners cut diagonally
- 3 Groove for induction loop
- 4 Induction loop

Assembly and installation

2. Lay the loop carefully into the groove and push it down by means of a blunt object, such as a piece of wood. The insulation must by no means be damaged.
3. To avoid slipping of the loop, fix the loop using small wooden wedges. Remove the wooden wedges later on.
4. Push the loop feed line through the empty conduit in place into the barrier housing.
5. Measure the induction loop according to chapter 8.4.3.
6. We recommend to cover the inserted loop using quartz sand. Make sure that at least 25 mm remain between the upper edge of the carriageway and the quartz sand for the potting compound.
7. Seal the groove with the potting compound.
 - The temperature resistance of the loop must match the temperature of the potting compound.
8. Allow the potting compound to cure.

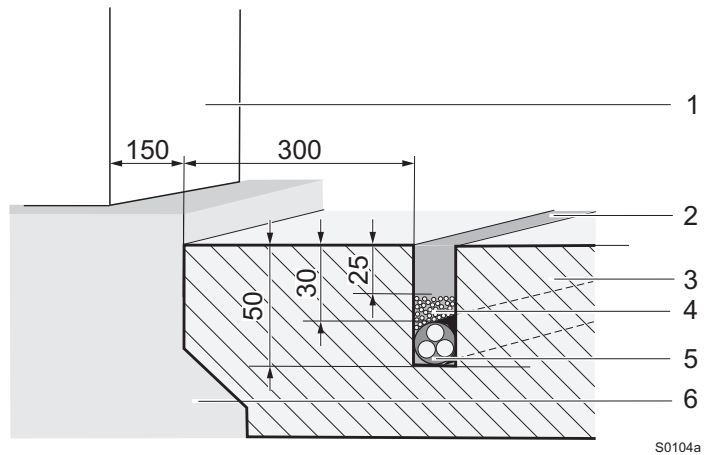
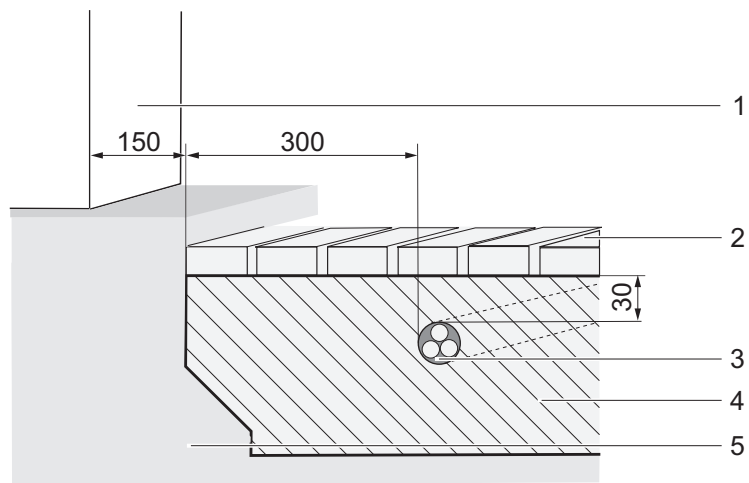

Fig. 20: Installing induction loop in bitumen, asphalt, or concrete

- 1 Barrier housing
- 2 Groove with potting compound
- 3 Asphalt surface
- 4 Quartz sand filling
- 5 Loop cable
- 6 Foundation

Assembly and installation

8.4.5 Installing induction loops under interlocking stone paving



S0105a

Fig. 21: Installing an induction loop under interlocking stone paving

- 1 Barrier housing
- 2 Paving
- 3 Loop cable
- 4 Sand bed
- 5 Substructure

When installing induction loops under interlocking stone paving, following points must be observed additionally:

- Use only pre-assembled cables provided by MAGNETIC (Type KAS 1 to KAS 5).
- Install the induction loop in sand only. The induction loop must not be installed in gravel or split.
- The induction loop must not slip or shift or be damaged during later vehicle traffic.
- Keep a minimum clearance between paving and loop cable of approx. 30 mm.

8.5 Unpacking

The individual packages are packed according to the expected transport conditions. Only environment-friendly materials have been used for the packaging.

The packaging should protect the individual components against transport damages, corrosion, etc up to the assembly. Therefore do not destroy the packaging and remove only directly before assembly.

1. Unpack barrier.
2. Set up barrier housing vertically.
3. Lay down barrier boom.
4. Unpack and lay out accessories.
5. Separate material according to type and size and recycle them after use.

8.6 Assemble housing

The barrier housing is attached by 4 foundation anchors via 2 attachment profiles. The attachment profiles are included in delivery. You can order a mounting set consisting of foundation anchor, washers, spring rings and hexagon head screws from MAGNETIC Autocontrol GmbH as accessories.

Requirements mounting material

If you are using your own mounting material, it must meet the following requirements:

- 4 foundation anchors: Fischer reaction anchor with glue cartridge RM 16 and sleeve with inner thread RG18 x 125 M12
- 4 washers DIN 9021 d17, zinc-plated
- 4 washers DIN 9021 d13, zinc-plated
- 4 spring washers DIN 128 A1, zinc-plated
- 4 hexagon head screws DIN 934 M12 x 55 8.8, zinc-plated.

Assembly and installation

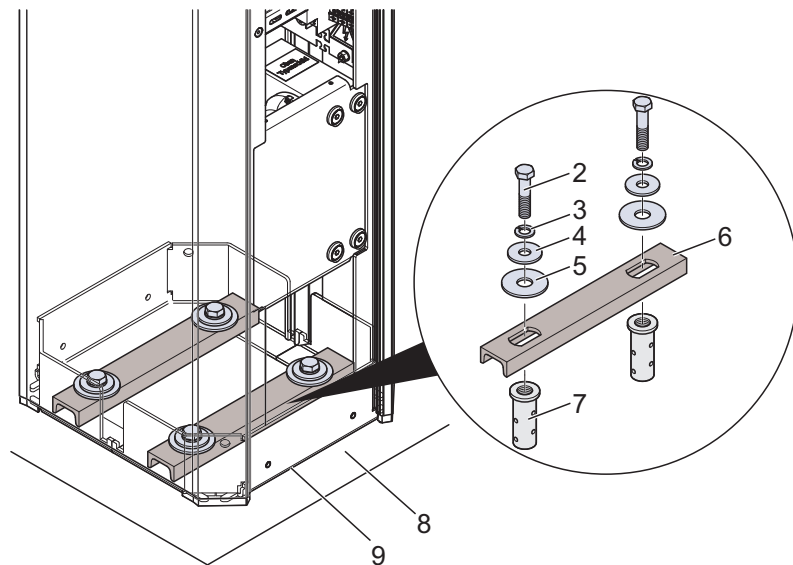

Mag00378a

Fig. 22: Assemble housing

- 1 Barrier housing
- 2 Hexagon head screws
- 3 Spring washer
- 4 Disc d13
- 5 Disc d17
- 6 Mounting profile
- 7 Sleeve with inner thread
- 8 Foundation
- 9 Silicon sealant

Assemble housing

1. The foundation must have cured.
2. Drill holes for the sleeves with inner threads according to the foundation plan. For Access XL see page 46, Fig. 12 and for Access XXL see page 48, Fig. 14. Compliance with the indicate sizes.
3. Set sleeves with inner thread according to the enclosed instructions.
4. Set up barrier housing upright on foundation.
5. Assemble the barrier housing on the foundation according to Fig. 22. Tighten hexagon head screws slightly for this.
6. Align barrier housing. Tighten the hexagon head screws firmly. If a nesting post or light barrier post is installed, observe page 79, chapter 8.14.
7. Seal barrier housing with silicon sealant.

8.7 Assemble nesting post or light barrier post

The nesting post and the light barrier post are attached with 4 foundation anchors each. You can order a mounting set consisting of foundation anchor, washers, spring rings and hexagon nuts from MAGNETIC Autocontrol GmbH as accessories.

Requirements mounting material

If you are using your own mounting material, it must meet the following requirements:

- 4 foundation anchors:
 - Features: suitable for concrete C35/45 XD3 XF2
 - Material: Stainless steel
 - Size: M8 x 110
 - Tensile strength: at least 9 kN
Foundation anchors that are optionally available from MAGNETIC achieve the tensile strength of 9 kN at a drilling depth of 80 mm.
- 4 washers DIN 9021 d8,4, stainless steel
- 4 spring washers DIN 128 A8, stainless steel
- 4 hexagon nuts DIN 934 M8, stainless steel

Assemble nesting post or light barrier post

1. The foundation must have cured.
2. Drill holes for the foundation anchors according to the foundation plan, page 51, Fig. 17. In compliance with the indicated sizes.
 - Drill-hole distance: 100 mm, square alignment
 - Diameter: 10 mm
 - Depth: 80 mm
(At this drilling depth, a minimum tensile strength of 9 kN must be guaranteed.)
3. Set four foundation anchors M8 x 110.
4. Set up post upright on foundation.
5. Attach the post to the foundation with the anchor bolts and tighten the nuts securely.

Assembly and installation

8.8 Assemble safety light barrier

Only MAGNETIC safety light barriers must be used.

8.8.1 Assemble transmitter

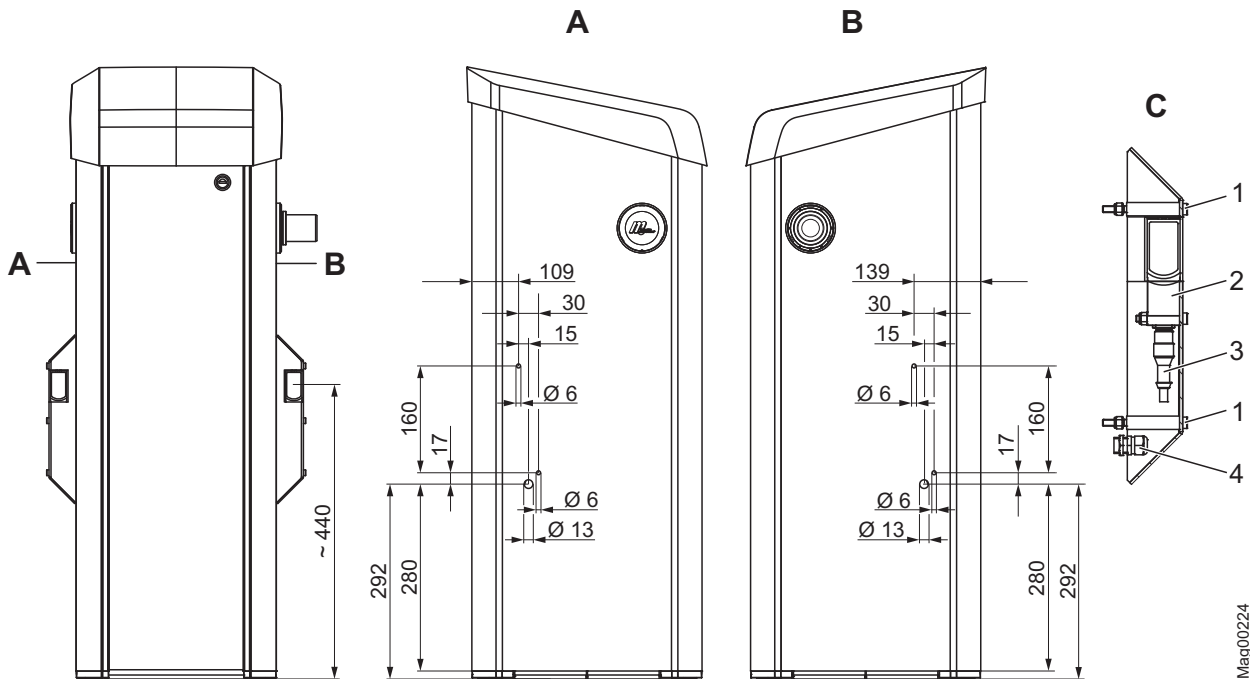

Fig. 23: Assemble of the transmitter's light barrier housing on the barrier housing

- A View A
 B View B
 C Light barrier housing transmitter

- 1 Hexagon socket screws 5 AF
 2 Transmitter
 3 Transmitter connection line
 4 Cable screw connection

1. Drill holes for the light barrier housing according to Fig. 23. Mount the cable screws at the housing with locknuts.
2. Connect connection line for transmitter to the control unit.
3. Guide connection line through cable screws.
4. Mount light barrier housing to housing with the hexagon socket screws 5 AF.

8.8.2 Assemble receiver

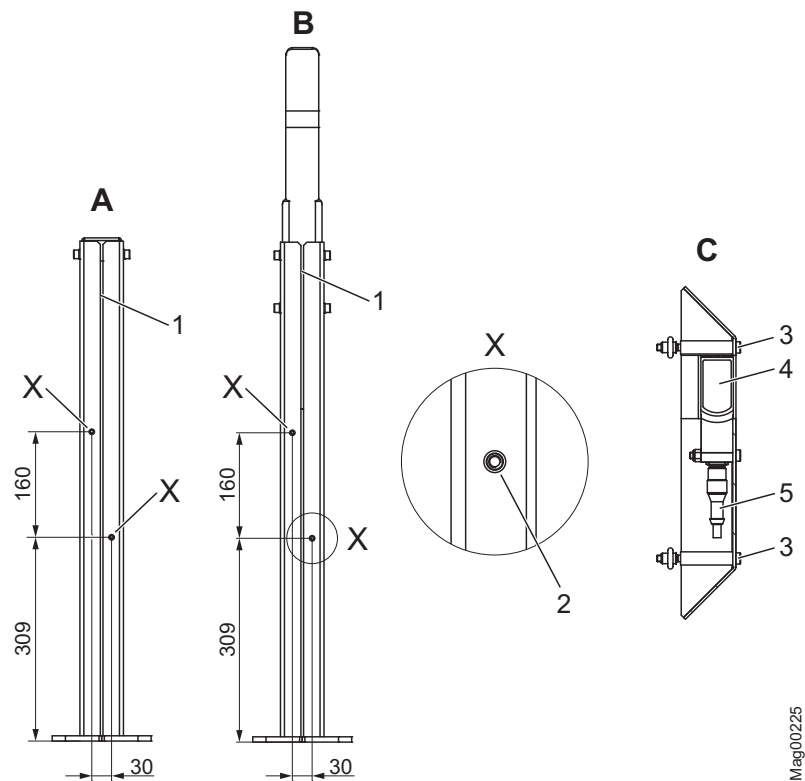

Mag00225

Fig. 24: Assemble the receiver's light barrier housing on the post

- A** Light barrier post
B Nesting post
C Light barrier housing

1 Gap
2 Drill holes for blind rivet nut
3 Hexagon socket screws 5 AF
4 Receiver
5 Receiver connection line

1. Press the two blind rivet nuts into the two intended bores at the post.
2. Guide the connection line for receiver through the gap in the post.
3. Connect connection line for receiver to the receiver.
4. Mount light barrier housing to housing with the hexagon socket screws 5 AF
5. Close empty conduits with construction foam to prevent water from entering them.

Assembly and installation

8.9 Assemble barrier boom up to 6 metres

Danger of injury

⚠ CAUTION!	
	<p>Danger of injury!</p> <p>There is a danger of injury when mounting the barrier boom.</p> <p>Therefore:</p> <ul style="list-style-type: none"> – Mount barrier boom by two persons.

1. Secure barrier danger area e.g. with barrier tape.
2. Remove the barrier housing hood.
3. Remove the barrier housing door.



WARNING!

Danger of crushing between barrier boom and barrier housing!

4. Switch off power supply. Ensure that the system is powered down. Secure against reactivation. The balancing springs in the lever system are relaxed. The flange is vertical.
5. Assemble barrier boom with hexagon head screws, washers, spring washers and nuts.

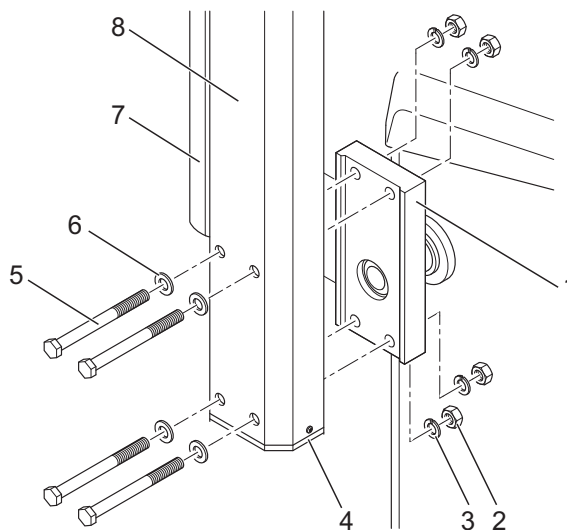





Fig. 25: Assembling the barrier boom

- 1 Flange
- 2 Nut (4 pieces)
- 3 Spring disc (4 pieces)
- 4 End cap (2 pieces)
- 5 Hexagon head screws (4 pieces)
- 6 Washer (4 pieces)
- 7 Edge protection (mount after barrier boom assembly)
- 8 Barrier boom

6. Mount end caps.
7. Check the vertical alignment of the barrier boom with a spirit level and correct if required. Turn the flange shaft for correction. Proceed as follows for this:
 - Loosen the 4 hexagon socket screws SW 10 at the two clamping levers. → See page 65, Fig. 28.
 - Turn the flange shaft.
 - Tighten the 4 hexagon socket screws SW 10 at the two clamping levers at 120 Nm.
8. Switch on power supply.
9. Switch the "Service" switch on the control unit. The LED lights red. The display backlighting flashes.
→ See page 116, chapter 10.7.7 Mode "Service".
10. Manually close the barrier with the middle right button  at the control unit.
11. Check horizontal alignment of the barrier boom with the spirit level.
12. Assemble edge protection. → See page 66, chapter 8.11.
13. Switch the "Service" switch on the control unit. The LED must light green.
14. Install the barrier housing door.
15. Attach and lock the barrier housing hood.

8.10 Assemble barrier boom as of 6 metres

Danger of injury

 CAUTION!	
	<p>Danger of injury!</p> <p>There is a danger of injury when mounting the barrier boom.</p> <p>Therefore:</p> <ul style="list-style-type: none"> – Mount barrier boom by two persons.

Scope of delivery

Barrier booms as of 6 metres are delivered in two packages. The packages comprise the following content:

- Package 1: Large boom profile with a length of up to 5 metres with already installed connector. Edge protection and end caps are loosely included.
- Package 2: Small boom profile.

Assembly and installation

Assemble barrier boom

1. Push small boom profile onto connector of the large boom profile.

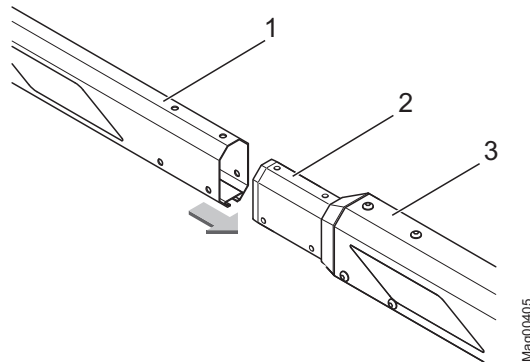

Fig. 26: Push small boom profile onto connector.

- 1 Small boom profile
- 2 Connector
- 3 Large boom profile

2. Mount the small boom profile with 6 screws to the large boom profile.

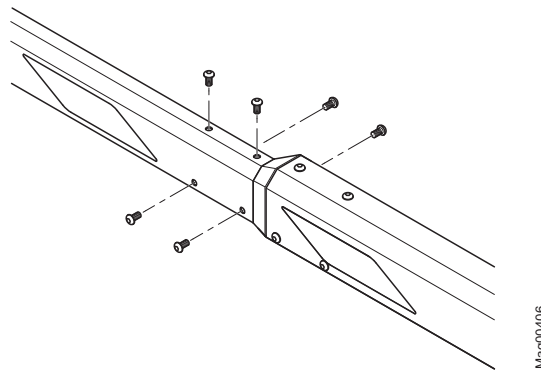

Fig. 27: Mount the small boom profile.

Schrankenbaum montieren

1. Secure barrier danger area e.g. with barrier tape.
2. Remove the barrier housing hood.
3. Remove the barrier housing door.



WARNING!

Danger of crushing between barrier boom and barrier housing!

4. Switch off power supply. Ensure that the system is powered down. Secure against reactivation. The balancing springs in the lever system are relaxed. The flange is vertical.

Assembly and installation

5. Put the flange in the horizontal position. Proceed as follows for this:
 - Loosen the 4 hexagon socket screws SW 10 at the two clamping levers.
 - Turn the flange shaft.

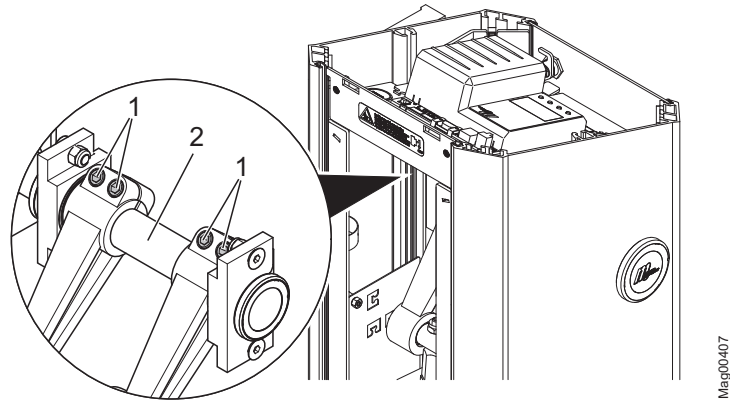

Fig. 28: Loosen hexagon socket screws at the clamping lever

- 1 Hexagon socket head screws M12 (SW10)
- 2 Flange shaft

6. Assemble barrier boom with hexagon head screws, washers, spring washers and nuts.

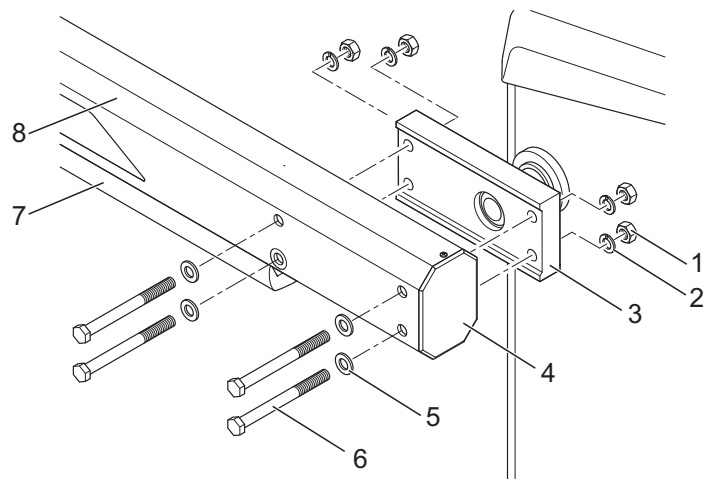



Fig. 29: Mount barrier boom



- 1 Nut (4 pieces)
- 2 Spring disc (4 pieces)
- 3 Flange
- 4 End cap (2 pieces)
- 5 Washer (4 pieces)
- 6 Hexagon head screws (4 pieces)
- 7 Edge protection (mount after boom assembly).
- 8 Barrier boom

Assembly and installation

7. Set the barrier to the vertical position with 2 persons.
8. Check the vertical position with a spirit level and correct if required. Turn the flange shaft for correction. → See page 65, Fig. 28.
9. Tighten the 4 hexagon socket screws SW 10 to 120 Nm at the two clamping levers.
10. Switch on power supply.
11. Switch the "Service" switch on the control unit. The LED lights red. The display backlighting flashes.
→ See page 116, chapter 10.7.7 Mode "Service".
12. Manually close the barrier with the middle right button  at the control unit.
13. Check horizontal alignment of the barrier boom with the spirit level.
14. Assemble edge protection. → See page 66, chapter 8.11.
15. Mount end caps of the barrier boom.
16. Switch the "Service" switch on the control unit. The LED must light green.
17. Install the barrier housing door.
18. Attach and lock the barrier housing hood.

8.11 Assemble edge protection

Missing edge protection at the barrier boom

 WARNING!	
	<p>Danger from missing edge protection at the barrier boom!</p> <p>Missing edge protection at the barrier boom may cause severe or lethal injuries for persons, bicyclers, cabriolet drivers and motorcycle drivers when the barrier boom closes!</p> <p>Therefore:</p> <ul style="list-style-type: none"> – Assemble edge protection. – If the edge protection is damaged, it must be replaced immediately.



NOTE!

If you use a pendulum support, observe that you must mount part of the edge protection in front of the pendulum support and part of the edge protection behind the pendulum support.

The edge protection is included in the delivery loosely in 2 m pieces. Large and small edge protection is included with barrier booms above 6 metres.

If the barrier was ordered with the "light strip" option, the barrier boom is delivered with the mounted edge protection.



The number of edge protections is according to the length of the long barrier boom profile.

1. Measure the length of the long barrier boom profile.
2. Shorten edge protection to the required length with a saw. When the length of the barrier boom profile is, for example, 5 m, saw off one edge protection to 1 m.
3. Moisten lateral lower area of the barrier boom onto which the edge protection is pushed with water.
4. Slide edge protection in the barrier boom groove.
5. Slide further edge protections into the intended groove until the edge protection ends flush with the barrier boom.

8.12 Conversion "left version" – "right version"

8.12.1 Converting barrier boom up to 6 metres

Danger of injury

 CAUTION!	
	<p>Danger of injury!</p> <p>There is a danger of injury when mounting the barrier boom.</p> <p>Therefore:</p> <ul style="list-style-type: none"> – Mount barrier booms by two persons.

All MHTM™ MicroDrive barriers are available as "left version" and "right version". → See type code, page 26 and as of page 27, Fig. 3.

If required, you can also remove the barrier boom yourself from one side of the barrier housing and replace it on the other.

1. Secure barrier danger area e.g. with barrier tape.
2. Remove the barrier housing hood.
3. Remove the barrier housing door.



WARNING!

Danger of crushing between barrier boom and barrier housing!

4. Switch off power supply. Ensure that the system is powered down. Secure against reactivation. The balancing springs in the lever system are relaxed. The barrier boom is vertical.

Assembly and installation

5. Write down control size between the balancing springs. The control size is the size between the upper edge of the upper spring traverse to the lower edge of the lower spring traverse.
6. Remove barrier boom. → See page 65, Fig. 29.
7. Relive balancing springs. The flange must be upright for this.
8. Perform Steps 6 to 8 according to chapter 8.13.1.
→ See page 73.
9. Unhook balancing springs.
10. Loosen the 4 hexagon socket screws SW 10 at the two clamping levers. Do not remove the hexagon socket screws.

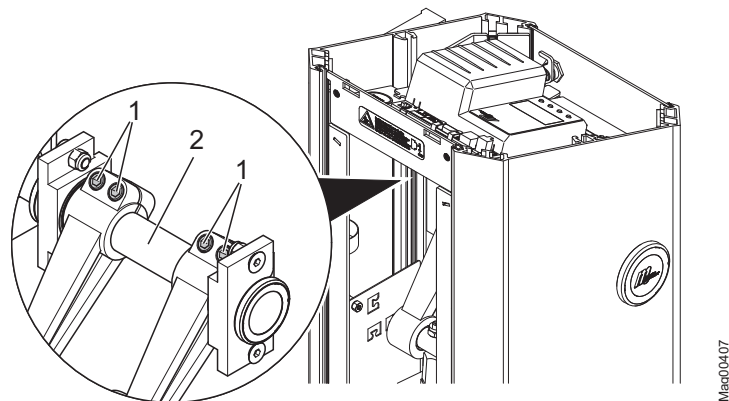



Fig. 30: Loosen hexagon socket screws.



- 1 Hexagon socket head screws M12 (SW10)
- 2 Flange shaft

11. Remove the flange shaft cover disc of the barrier housing. Push a long rod through the flange shaft for this and slightly push it against the cover.
12. Pull out the flange shaft with the flange by rotating movements. We recommend following up with a pipe or rod with a similar diameter as the flange shaft.
13. Insert the flange shaft with the flange from the other side by rotating movements to the stop of the flange. Observe correct seat of the V-ring. The sealing lip must be flush against the plane area of the plastic ring.

14. Put the flange in the horizontal position by turning the flange shaft.
15. Hook in balancing springs.
16. Apply cover disc for the flange shaft.
17. Check and, if necessary, adjust vertical position by spirit level.
18. Tighten the 4 hexagon socket screws SW10 at the two clamping levers at 120 Nm. Observe that the two clamping levers and the adjusting washers are each flush with the ball bearing. The clamping levers must be pushed against the ball bearings.
19. Mount the barrier boom with the flange vertical.
20. Adjust balancing springs with the noted control size.
→ See page 73, chapter 8.13.1, Steps 8 to 13.
21. Switch on power supply.
22. Switch the "Service" switch on the control unit. The LED lights red. The display backlighting flashes.
→ See page 116, chapter 10.7.7 Mode "Service".
23. Manually close the barrier with the middle right button  at the control unit.
24. Check horizontal alignment of the barrier boom with the spirit level.
25. Switch the "Service" switch on the control unit. The LED must light green.
26. Install the barrier housing door.
27. Attach and lock the barrier housing hood.

8.12.2 Converting barrier boom as of 6 metres

Danger of injury

 CAUTION!	
	<p>Danger of injury!</p> <p>There is a danger of injury when mounting the barrier boom.</p> <p>Therefore:</p> <ul style="list-style-type: none"> – Mount barrier booms by two persons.

All MHTM™ MicroDrive barriers are available as "left version" and "right version". → See type code, page 26 and as of page 27, Fig. 3.

If required, you can also remove the barrier boom yourself from one side of the barrier housing and replace it on the other.

1. Secure barrier danger area e.g. with barrier tape.
2. Remove the barrier housing hood.
3. Remove the barrier housing door.

Assembly and installation



WARNING!

Danger of crushing between barrier boom and barrier housing!

4. Switch off power supply. Ensure that the system is powered down. Secure against reactivation. The balancing springs in the lever system are relaxed. The barrier boom is vertical.
5. Write down control size between the balancing springs. The control size is the size between the upper edge of the upper spring traverse to the lower edge of the lower spring traverse.
6. Relieve balancing springs. The flange must be upright for this.
7. Perform Steps 6 to 8 according to chapter 8.13.1.
→ See page 73.
8. Loosen the 4 hexagon socket screws SW 10 at the two clamping levers. Do not remove hexagon socket screws.
9. Turn the flange shaft as far as the barrier boom tip touches the ground. Perform step by 2 persons.

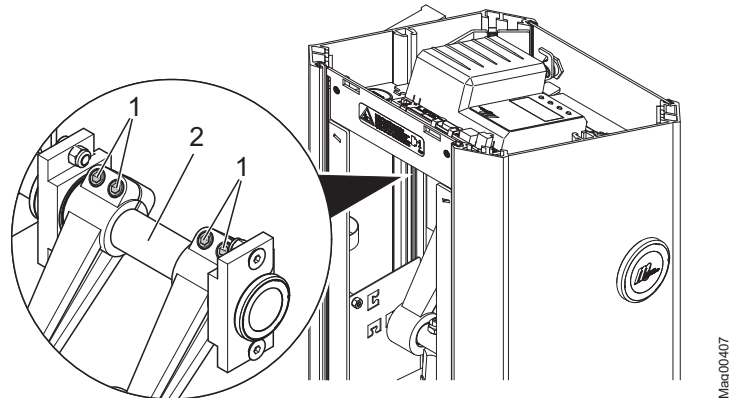



Fig. 31: Loosen hexagon socket screws.

- 1 Hexagon socket head screws M12 (SW10)
- 2 Flange shaft



10. Remove barrier boom. → See page 65, Fig. 29.
11. Unhook balancing springs.
12. Remove the flange shaft cover disc of the barrier housing. Push a long rod through the flange shaft for this and slightly push it against the cover.

13. Pull out the flange shaft with the flange by rotating movements. We recommend following up with a pipe or rod with a similar diameter as the flange shaft.
14. Insert the flange shaft with the flange from the other side by rotating movements to the stop of the flange. Observe correct seat of the V-ring. The sealing lip must be flush against the plane area of the plastic ring.
15. Put the flange in the vertical position by turning the flange shaft.
16. Hook in balancing springs.
17. Apply cover disc for the flange shaft.
18. Put the flange in the horizontal position by turning the flange shaft.
19. Mount the barrier boom with 2 persons with the horizontal flange.
20. Set the barrier to the vertical position with 2 persons.
21. Check the vertical position by spirit level and if necessary adjust it.
22. Tighten the 4 hexagon socket screws SW10 at the two clamping levers at 120 Nm. Observe that the two clamping levers and the adjusting washers are each flush with the ball bearing. The clamping levers must be pushed against the ball bearings.
23. Adjust balancing springs with the noted control size.
→ See page 73, chapter 8.13.1, Steps 8 to 13.
24. Switch on power supply.
25. Switch the "Service" switch on the control unit. The LED lights red. The display backlighting flashes.
→ See page 116, chapter 10.7.7 Mode "Service".
26. Manually close the barrier with the middle right button  at the control unit.
27. Check horizontal alignment of the barrier boom with the spirit level.
28. Switch the "Service" switch on the control unit. The LED must light green.
29. Install the barrier housing door.
30. Attach and lock the barrier housing hood.

Assembly and installation

8.13 Check and set the balancing springs in the lever system

Danger of crushing, lever system!

 WARNING!	
	<p>Danger of crushing at opened barrier housing at the lever system!</p> <p>The lever system in the barrier housing can cause serious crushing injuries!</p> <p>Therefore:</p> <ul style="list-style-type: none"> – Balancing springs in the lever system must only be checked and adjusted by specialised personnel. – Balancing springs must only be checked and adjusted with the power supply turned off – Wear protective gloves if necessary.

ACHTUNG!	
	<p>The barrier system can be damaged by improper repair!</p> <p>Other considerable damage may result from improper repair.</p> <p>Therefore:</p> <ul style="list-style-type: none"> – Replace all springs if a spring is broken.

The lever system has balancing springs that exactly balance the barrier boom weight. These balancing springs are pre-set in the factory. The precise setting must be performed after assembly of the barrier boom and before commissioning.

The lever force is determined not only by the spring tension but also by the number of springs used and the spring rate. MAGNETIC uses two spring types. Depending on application case, you will have to set the spring tension, remove the springs, use additional springs or use springs with a different spring rate.
→ Also see page 76, chapter 8.13.2.

In the "Power failure" menu, you can set the barrier behaviour in case of voltage failure. → Refer to Page 130, Chapter 10.10.9. The settings in this menu do not influence the settings of the balancing springs.

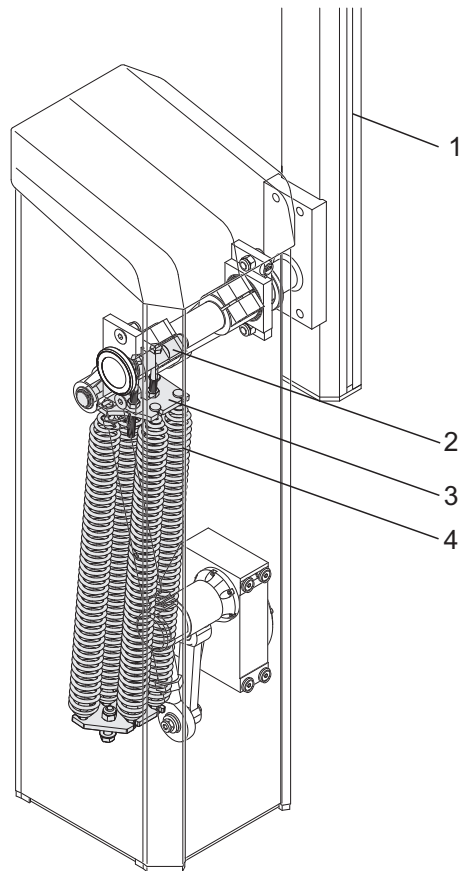

Mag00377

Fig. 32: Balancing springs in the lever system.

- 1 Barrier boom
- 2 Spring shaft
- 3 Upper spring traverse
- 4 Balancing spring

8.13.1 Setting balancing springs

Check and adjust balancing springs

Check balancing springs with the motor warm from operation.

1. Secure barrier danger area e.g. with barrier tape.



WARNING!

Danger of crushing between barrier boom and barrier housing!

2. Switch off power supply. Ensure that the system is powered down. Secure against reactivation.

Assembly and installation

3. Manually put the barrier boom in the 30°-position. If required, push the lever arm from the dead point manually via the coupling rod. → See page 162, chapter 13.5.
4. Let go of barrier boom.
 - If the barrier boom stays in the 30° position, the balancing springs are set correctly.
 - If the barrier boom does not stay in the 30° position, the balancing springs must be adjusted. If the barrier boom opens after it released from the 30° position, the balancing springs are too strongly pre-tensioned. If the barrier boom closes after it released from the 30° position, the balancing springs are too weakly pre-tensioned.

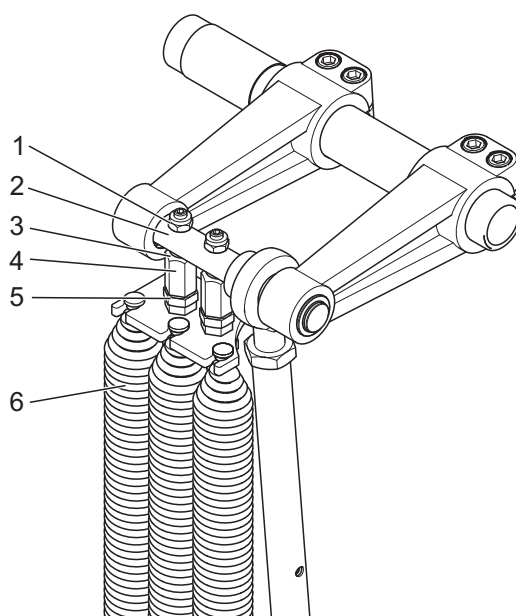

Mag00379a

Fig. 33: Adjust balancing springs

- 1 Nut M10
- 2 Spring shaft
- 3 Cone hexagon shaft SW22
- 4 Hexagon shaft SW22
- 5 Counter nut M16
- 6 Balancing spring

5. Put the barrier boom in the vertical position. The balancing springs are relieved.
6. Unscrew the M16 nuts (Fig. 33, item 5) evenly. Hold the respective hexagon shaft SW22 for this.
7. Unscrew the M10 nuts (Fig. 33, item 1) evenly. For this, hold the respective hexagon shaft SW22 until the cone of the hexagon shaft is clearly free (approx. 2 mm).
8. Use a wrench to alternatingly turn the hexagon shafts in the respective direction by approx. one turn.
 - Increasing spring tension: Turn hexagon shafts clockwise.
 - Reducing spring tension: Turn hexagon shafts counter clockwise.
9. Check parallelism of the upper spring traverse to the spring shaft. For this, measure the distance between the upper spring traverse and the spring shaft at both ends of the spring traverse.
10. Tighten the two M10 nuts evenly with a torque of 50 Nm. The cones of the hexagon shafts SW22 must be gripped by the spring shaft again. Check again that the spring shaft is parallel to the spring traverse and correct if required.
11. Counter M16 nuts against the spring traverse.
12. Check barrier boom position according to step 4.
13. If required, repeat steps 8 to 12 until the barrier boom is balanced in the 30° position.
14. Install the barrier housing door.
15. Attach and lock the barrier housing hood.

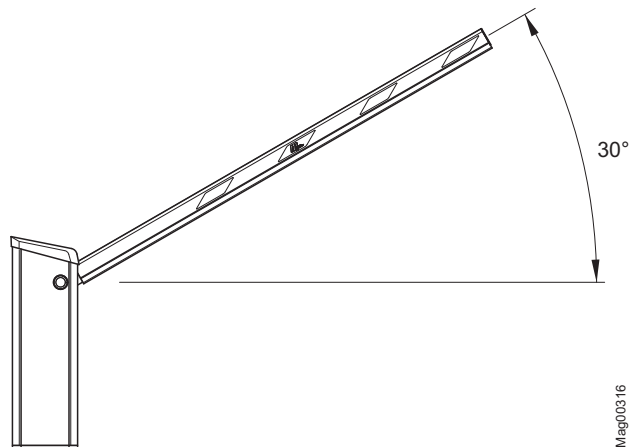

Fig. 34: Opening angle barrier boom 30°

Assembly and installation

8.13.2 Overview table balancing springs



NOTE!

The following overview tables "Balancing springs" do not take into consideration any attachment parts. For barrier booms with attachment parts, the required number of springs may deviate from the number of springs in the overview table.

The following overview table apply for the barriers Access XL.

Overview table balancing springs for barriers Access XL without pendulum support

Lane width [m]	Number springs weak	Number springs strong ¹⁾	Control size [mm] ²⁾
5.0	3	–	551
5.1	3	–	551
5.2	3	–	552
5.3	3	–	560
5.4	3	–	569
5.5	3	–	577
5.6	1	1	569
5.7	1	1	578
5.8	4	–	551
5.9	4	–	551
6.0	4	–	553
6.1	4	–	558
6.2	4	–	562
6.3	4	–	565
6.4	4	–	569
6.5	4	–	573
6.6	4	–	577
6.7	–	2	555
6.8	–	2	560
6.9	–	2	563
7.0	–	2	567
7.1	–	2	571
7.2	–	2	575
7.3	–	2	579
7.4	5	–	556
7.5	5	–	560

Assembly and installation

Lane width [m]	Number springs weak	Number springs strong ¹⁾	Control size [mm] ²⁾
7.6	5	–	564
7.7	5	–	567
7.8	5	–	571
7.9	5	–	575
8.0	5	–	578
8.1	1	2	562
8.2	1	2	566
8.3	1	2	569
8.4	1	2	573
8.5	1	2	577
8.6	1	2	581
8.7	1	2	584
8.8	2	2	551
8.9	2	2	553
9.0	2	2	556
9.1	2	2	559
9.2	2	2	563
9.3	2	2	566
9.4	2	2	570
9.5	2	2	573
9.6	2	2	577
9.7	–	3	572
9.8	–	3	576
9.9	–	3	579
10.0	3	2	557

1) The strong springs are marked with a yellow dot at the suspension bolt.

2) Control size: Size between the upper edge of the upper spring traverse to the upper edge of the lower spring traverse

Table 13: Overview table balancing springs for barriers Access XL without pendulum support

Assembly and installation

8.13.3 Arrangement of balancing springs

The balancing springs are aligned as follows for the barriers Access XL.

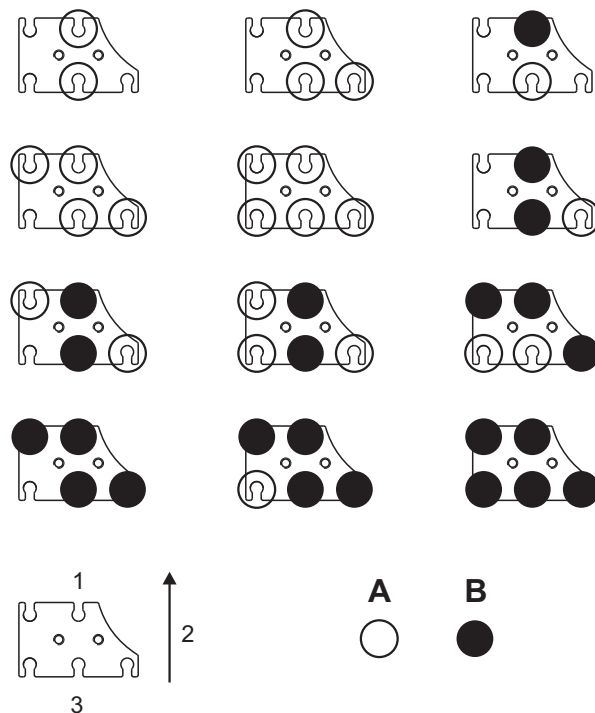

Fig. 35: Arrangement of balancing springs

- 1 Front
- 2 Barrier boom
- 3 Rear

- A Weak springs
- B Strong springs
(marked with a yellow dot at the suspension bolt.)

Mag00365

8.14 Align barrier housing and post

Falling components

WARNING!



Risk of injury from falling components!

Falling components such as the barrier housing can cause severe injury!

Therefore:

- When aligning the barrier housing and nesting post, loosen the attachment screws only slightly.
- Tighten the attachment screws again after alignment.



NOTE!

You can set the nesting post height. → See page 80, chapter 8.15.

Alignment conditions for nesting post

The barrier boom must run centrally into the nesting post fork.

Alignment conditions for light barrier

Transmitter and receiver of the light barrier must be aligned with each other for an object to be securely detected. For final alignment, transmitter and receiver must be electrically connected. → See page 90, chapter 9.4.4.

1. Slightly loosen the barrier housing and post attachment screws.
2. Align barrier housing and post with each other.
3. Tighten the barrier housing and post attachment screws again.
4. Seal barrier housing with a silicon sealant according to page 58, Fig. 22.

Assembly and installation

8.15 Set nesting post height

Danger of crushing

⚠ CAUTION!	
	<p>Crushing danger between the fork at the nesting post and the barrier boom!</p> <p>Fingers and hands can be crushed when the barrier boom runs into the nesting post when closing.</p> <p>Therefore:</p> <ul style="list-style-type: none"> – Switch off power supply during assembly. – Do not hold on to fork from the inside. Wear safety gloves if required.

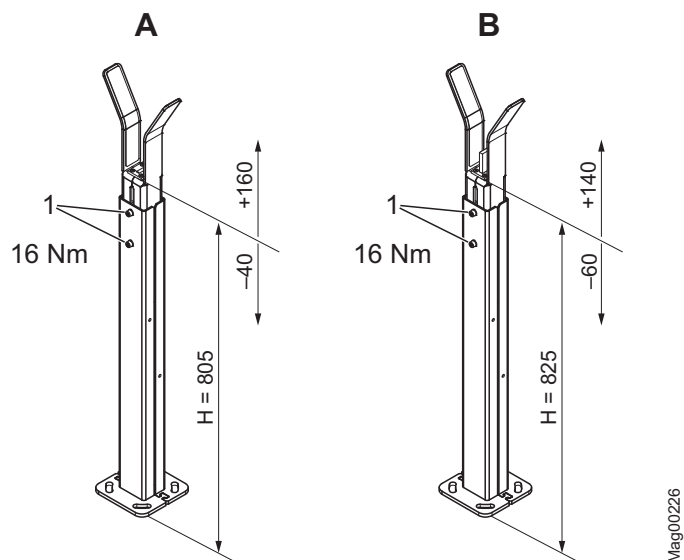

Fig. 36: Set nesting post height.

- A Nesting post
 B Nesting post with lock
 H Reference height
 1 Torx screws

You may set the nesting post height, e.g. to balance out level differences in the foundations.

1. Loosen the two Torx screws until the nesting post fork can be moved. Hold on to the fork.
2. Set the fork to the desired height.
3. Tighten the two Torx screws with 16 Nm.

8.16 Stick on prohibition signs

The delivery includes two prohibition signs as stickers. Attach the prohibition signs to the barrier boom according to the following drawing.

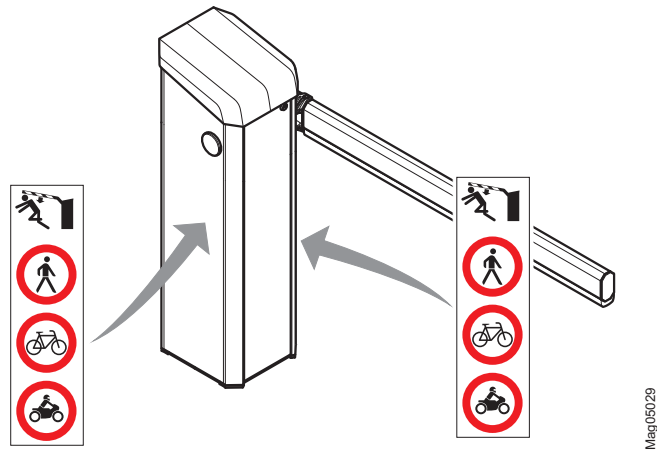

Fig. 37: Apply prohibition signs



NOTE!

When a motorcycle loop is installed, the lower prohibition sign must be cut off.

8.17 Check assembly and installation

The following points must be checked after assembly and installation of the barrier:

- Are all foundation anchors firmly fixed?
- Are all screws firmly tightened?
- Have all barrier housing covers been properly assembled?
- Are warning signs applied?

Electrical connection

9 Electrical connection

9.1 Safety

→ See also safety notes on page 17, chapter 2.6 "Occupational safety and special dangers".

Electric voltage

⚠ DANGER!	
	<p>Mortal danger by electric voltage!</p> <p>Touching live parts can be lethal. Damage to the insulation or to individual components can be lethal.</p> <p>Therefore:</p> <ul style="list-style-type: none"> – Switch off the power supply immediately in case of damage to the insulation and arrange repair. – Only electricians may carry out work on the electrical system. – Switch off power supply and secure against re-activation before performing any work. Test for absence of voltage! – Never bypass or deactivate fuses. – When replacing fuses observe the correct amperage specification. – Keep moisture and dust away from live parts. Moisture or dust may cause a short circuit. If the electrical connection is established during precipitation, e.g. rain or snow, penetration of moisture must be prevented by suitable measures, such as a protective cover.

General

⚠ WARNING!	
	<p>Danger by inappropriate installation!</p> <p>Inappropriate installation can cause severe or lethal injuries.</p> <p>Therefore:</p> <ul style="list-style-type: none"> – Only electricians must perform any electrical installation tasks. – Pay attention to tidiness and cleanness at the assembly site! Loosely stacked or lying around components and tools are accident sources. – Tighten all screws correctly.

Hot surfaces

⚠ CAUTION!	
	<p>Danger of burns!</p> <p>The motor surface may be hot. Touching this hot surface can lead to burns.</p> <p>Therefore:</p> <ul style="list-style-type: none"> – Do not touch these hot surfaces. – After switching off the power supply wait some minutes until the motor has cooled down. – Wear protective gloves if necessary.

Electromagnetic interference

NOTICE!	
	<p>Electromagnetic interferences may cause malfunctions of the barrier or adjacent devices!</p> <p>The barrier is approved for industrial, residential, commercial a business use. Operation in other electro-magnetic environmental conditions may cause interferences or malfunctions.</p> <p>Therefore:</p> <ul style="list-style-type: none"> – Place control lines and mains cables into separate conduits – Use cables according to the electrical circuit plan. – Only install and apply additional parts approved by MAGNETIC. – The electrical and electronically additional parts must be EMC verified and must not exceed the indicated EMC limit values.

Personal protective equipment

The following must be worn during all installation work:

- Work clothes
- Protective gloves
- Safety shoes
- Protective helmet.

9.2 Installing electrical protective devices

The safety installations that are required according to regional and local regulations must be provided by the customer. Usually these are:

- Residual current device (RCD)
- Circuit-breaker
- Lockable 2-pole main switch acc. to EN 60947-3.

Electrical connection

9.3 Connecting the power cable

Electric voltage

⚠ DANGER!



Mortal danger by electric shock!

If the mains supply is not connected to the terminal clamps correctly, loosens from the connection clamps and touches the housing or door, there is a direct danger to life from electric shock.

Therefore:

- Only electricians may carry out work on the electrical system.
- Connect power supply according to the following description.
- Install electrical protective devices according to chapter 9.2.



NOTE!

The wire cross-section of the mains line must be between 1.5 and 4 mm². Observe national provisions on line length and associated cable cross-section.



DANGER!

Mortal danger by electric voltage!

1. Disconnect barrier system power supply. Ensure that the system is powered down. Secure against reactivation.
2. Strip-off mains supply and cores according to the following figure.

Strip-off cable and core insulation – preparation of the wiring

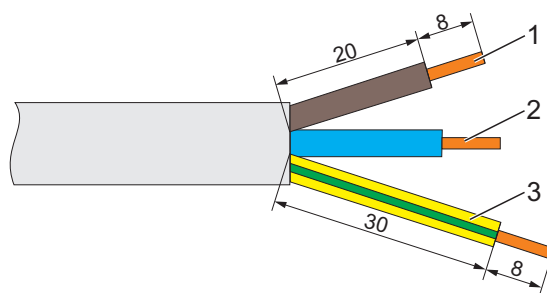

Mag00201

Fig. 38: Strip-off the mains supply

- 1 Phase
- 2 Zero conductor
- 3 Earth conductor

Mains supply placement

3. Connect the mains supply with the intended terminal clamps X1: L / N / PE) in the barrier housing according to the following figures → Also refer to page 168, chapter 17.1 "Wiring diagram".
 - Place mains supply properly in the barrier housing. The line must not get into moving components.
 - Attach power supply to the metal tabs with 2 cable ties.

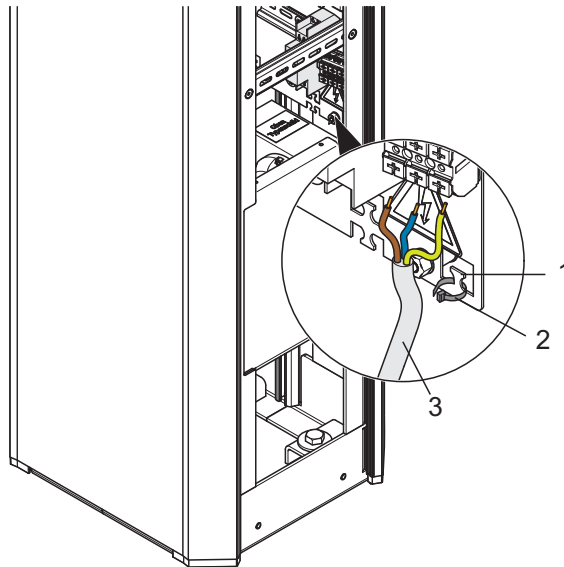

Mag00374

Fig. 39: Mains supply placement

- 1 *Cable tie metal tabs*
- 2 *Cable tie*
- 3 *Mains supply*

Electrical connection

Connecting mains supply

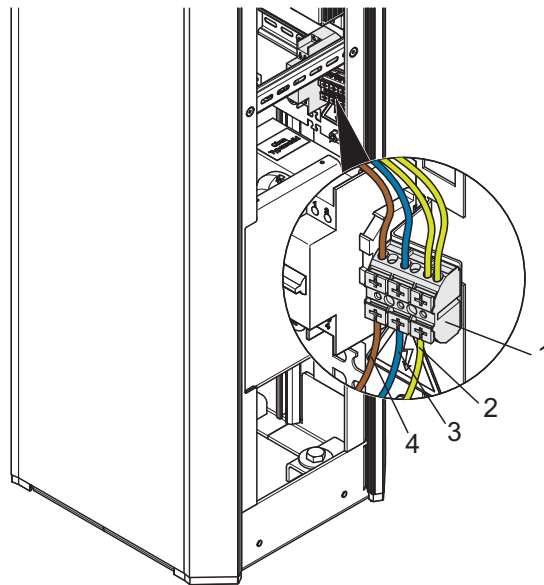

Mag00375

Fig. 40: Connecting the mains supply

- 1 Terminal clamps for mains supply
- 2 Earth conductor PE
- 3 Zero conductor N
- 4 Phase L

9.4 Connect customer's control lines (signalling devices)

The following connections are available for control and feedback on customer's side:

- 8 Digital inputs for controlling the barrier.
- 4 Digital outputs to feed back information.
- 6 Relays outputs to feed back information. 3 Relays are normally-open (NO) and 3 relays are change-over contacts.



DANGER!

Mortal danger by electric voltage!

1. Disconnect barrier system power supply. Ensure that the system is powered down. Secure against reactivation.

Connecting the control lines

2. Guide control lines into the connection space through the cable openings.
 - Steuerleitungen ordnungsgemäß hinter den Kabelklammern verlegen. The control lines must not get into moving components.
 - If necessary, attach control lines clamps to the metal tabs.
3. Connect control lines according to wiring diagram.
 - See page 168, chapter 17.1 "Wiring diagrams".

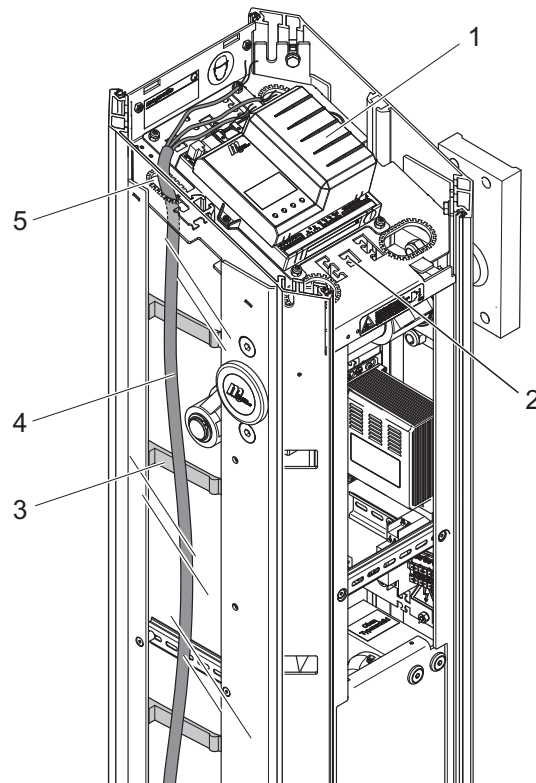

Megg00409

Fig. 41: Connecting the control lines

- 1 Control unit
- 2 Cable tie metal tabs
- 3 Cable clamp
- 4 Control line
- 5 Cable opening

Electrical connection

9.4.1 Connecting safety devices

As safety devices, you must connect safety loops or safety light barriers to the control unit. Safety loops must only be connected to monitor vehicles. Only MAGNETIC safety light barriers must be used.

If you connect a safety loop, the barrier closes only after the safety loop is clear. If you connect a safety light barrier, the barrier closes only after the safety light barrier is clear.

9.4.2 Plausibility check of the safety devices



NOTE!

The plausibility check is deactivated in barriers in deadman operation with a closing speed of ≥ 2.2 seconds.

To prevent the barrier from being operated without safety devices, a plausibility check of the safety devices is performed.

The plausibility check inspects whether at least one safety device is present and whether the safety device works correctly in operation.

When the voltage supply is switched on, it is verified that at least one safety device was passed by a vehicle or person within three barrier openings. In operation, the number is increased to ten barrier openings.

If the plausibility check fails, the barrier is decommissioned for reasons of safety. The message "Safety device missing" appears on the display.



NOTE!

The input function "Safety device" must only be used for additional safety devices. The input function is not considered for the plausibility check. A safety loop always has to be connected to the detector module or a testable safety light barrier to the clamps X11 and X20.

9.4.3 Connecting safety loop

The safety loop is connected to the plug-in module "Detector1 (A-B)", clamps A or clamps B. → See page 168, chapter 17.1 "Wiring diagrams".

The clamp function parameters can be set in the menu "Detector 1 (A-B)" with the parameters "Mode A" or "Mode B".

→ See page 137, chapter 10.15.

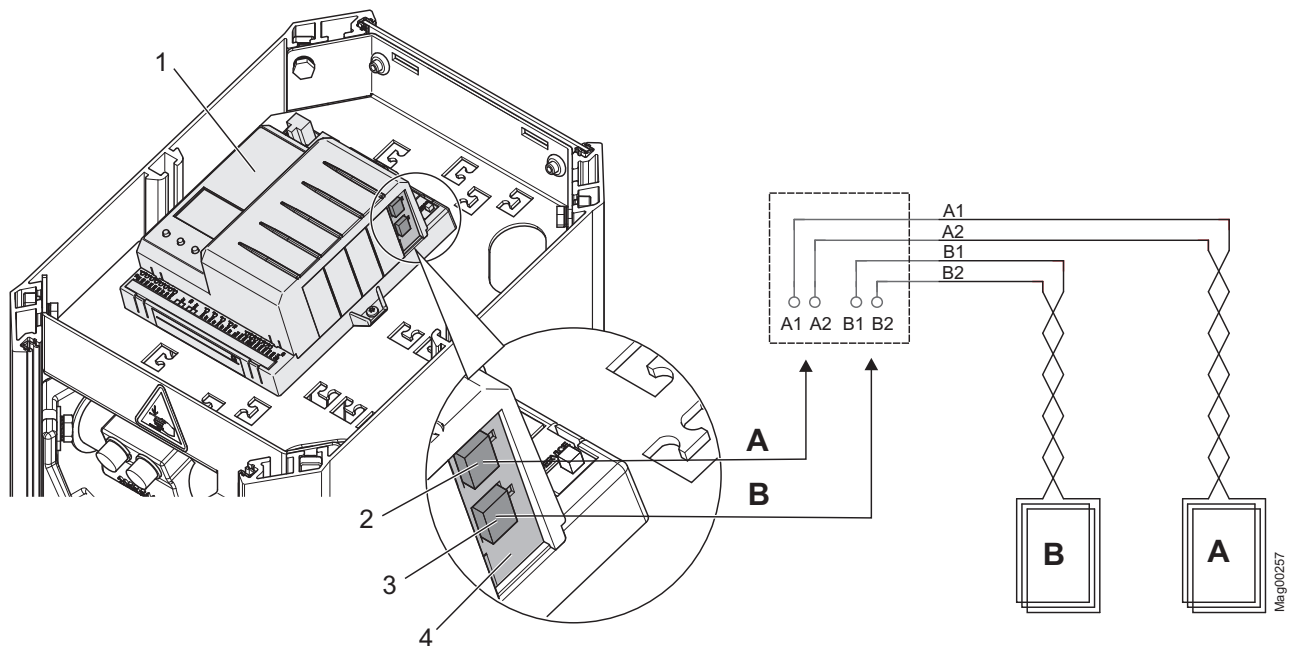

Fig. 42: Connecting safety loop

- 1 Control unit
- 2 Connection of induction loop A
- 3 Plug-in module "Detector 1 (A-B)"
- 4 Connection of induction loop B
- A Induction loop A
- B Induction loop B



NOTE!

If four induction loops must be supervised, you can connect another plug-in module with the "Detector" function into the control unit. This plug-in module registers as "Detector 2 (C-D)". To prevent mutual interference between the induction loops, we recommend using a plug-in module instead of an external detector.

Electrical connection

9.4.4 Connect and test the safety light barriers

Connecting safety light barrier

Connect the transmitter and receiver connection lines of the safety light barriers to clamps X11 and X20.

By default, MAGNETIC installs a jumper between terminals X11 OUT and IN. When a safety light barrier is connected, the jumper must be removed.

→ See page 168, chapter 17.1 "Wiring diagrams".

Aligning the safety light barrier

The receiver is mounted at the post and the transmitter at the barrier housing. Alternatively, the receiver can also be installed to an opposite barrier housing.

1. There must not be any objects between the transmitter and receiver. The light path must be free.
2. Switch on power supply.
3. The green LEDs at the transmitter and receiver must be lit.
4. Align receiver with transmitter. If required, hold the included reflective foil in front of the receiver as setting aid. The yellow LED at the receiver lights up when aligned correctly.

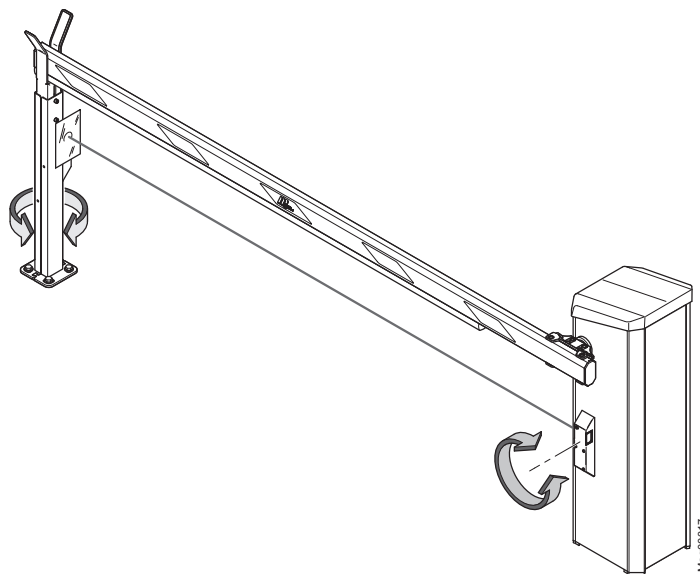

Fig. 43: Use reflective foil

- 1 Reflective foil
5. Slightly loosen the attachment screws from the post to align the receiver. It must be possible to turn the post.
6. Turn the post, until the yellow LED at the receiver is lit.
7. Keep reflective foil in the barrier housing.

Check safety light barrier function

Perform function test by holding an object into the light path between the transmitter and receiver.

The following items must be met:



- The yellow LED at the receiver must go out.
- The barrier cannot be closed.

9.4.5 Connecting emergency opening contacts

Fire-fighter switch, emergency opening contacts, etc. are connected to the "Open high priority" input. When the signal is applied to this input, the barrier opens. While the signal is present, the barrier cannot be closed.

→ See page 84, chapter 9.4.6 "Digital inputs" and page 168, chapter 17.1 "Wiring diagram".

9.4.6 Digital inputs
Improper parameterisation

 WARNING!	
	<p>Risk of injury by improper parameterisation of the control unit!</p> <p>Improper parameterisation of the control unit can lead to severe injuries!</p> <p>Therefore:</p> <ul style="list-style-type: none"> – The parameterisation of the control unit may only be carried out by qualified personnel or electricians. – The electrical connection of the signal generators to the IN1 to IN8 inputs must fit the parameterisation.

Technical data

→ See page 31, chapter 4.3.

NOTE!

The digital input functions can be freely parameterised. → For input parameterisation, refer to page 99, chapter 10.

Electrical connection

Factory setting

Clamp	Description	Function
IN1	Input 1	Open low priority
IN2	Input 2	Open low priority
IN3	Input 3	Opening with vend count
IN4	Input 4	Open high priority
IN5	Input 5	External opening loop exit
IN6	Input 6	Close
IN7	Input 7	Close
IN8	Input 8	Boom contact

Table 14: Factory settings "Digital inputs"

The functions have different priorities towards each other. The function "Open high priority" has the highest priority (priority 1). I.e. all other functions, such as "Open low priority", "Close", etc. are ignored if the function "Open high priority" is active.

Function	Description
Open high priority	Connect fire fighter switch, emergency opening contacts, etc. to this input. This input has the highest priority. The barrier opens when +24 V DC are applied to this input. While the signal is present, the barrier cannot be closed. This input must not be used for opening loops. This input function is superordinated to all other input functions.
Open low priority <ul style="list-style-type: none"> ■ Programme modes 2, 4 to 8: Open low priority ■ Programme mode 3: Close/Open 	<ul style="list-style-type: none"> ■ Depending on programme mode, a permanent signal or impulse is required. ■ Programme modes 2, 4 to 8: The barrier opens when +24 V DC are applied to this input. ■ Programme mode 3: The barrier changes its state with every impulse, i.e. the barrier closes or opens.
Open exit ¹⁾	This function is used for selective counting, e.g. for permanent renters of a parking space.
Opening with vend count ¹⁾	An internal vend count counts the impulses present at this input. The impulse must be present for approx. 100 to 300 ms. The reset behaviour of the vend count can be set by the "Reset behaviour" parameter.
Close	Depending on programme mode, a permanent signal or impulse is required. The barrier closes when +24 V DC are applied to this input.
Close low priority	The function "Close low priority" is subordinated to all opening functions. The barrier closes when +24 V DC are applied to this input.
Inhibit opening	When +24 V DC are applied to this input, all opening commands except for the "Open high priority" and "Open exit" signals are ignored. This input function has no function in the programme modes 1 to 4.
Inhibit opening loop	If the input function is active, the barrier remains closed when the opening loop is driven on.
Inhibit signal light	Signal lights are no longer controlled when +24 V DC are applied to this input.

Function	Description
External opening loop entry ¹⁾	The barrier opens when +24 V DC are applied to this input. Connect external opening loops to this input.
External opening loop exit ¹⁾	The barrier opens when +24 V DC are applied to this input. Connect external opening loops to this input.
External impact detection	<p>You can install external impact detection to the barrier boom. While no vehicle touches the barrier boom from below, the input "External Impact detection" has +24 V DC applied. When the barrier boom impacts a vehicle, e.g. due to impermissible driving through of a vehicle, the +24 V DC are removed from the input "External impact detection".</p> <p>The barrier's behaviour in case of impact detection can be set in the "impact settings" menu. → See page 124, chapter 10.10.7.</p>
Boom contact input	<p>The barrier is equipped with a boom release input in the flange. While the barrier boom is in its correct position, +24 V DC are applied to the "Boom contact input" input. When the barrier boom is moved from its position e.g. by a collision with a vehicle, the +24 V DC are removed from the "Boom contact input" input. The barrier moves into the "open" position.</p> <p>The boom contact must be activated in the menu "Boom contact settings". → Refer to Page 135, Chapter 10.11.2</p>
Safety device	<p>For operation +24 V DC must be applied at this input. You can implement this as follows:</p> <ul style="list-style-type: none"> ■ via a safety device with potential-free contact ■ via a wire bridge, connected to +24 V DC <p>The barrier cannot be closed if the input signal +24 V is interrupted.</p> <p>If the barrier is in the process of closing and the +24 V input signal is interrupted and the cut-off angle is not undercut yet, the barrier opens again</p> <p>This input must only be used in addition to the internal detector module or/and the safety light barriers connected to clamp X11. Only the internal safety devices are monitored.</p>
Acknowledgment	This input is required for parallel operation. → For more information on parallel operation, see separate instructions.
Blink signal light	While +24 V DC are pending at the input, the lamps flash at 1 Hz. This input overwrites the function of the red signal lamps. You may use this function for special signalling like "Parking place assigned".

1) The parameter is only sensible for the automatic programme modes 5 to 8.

Table 15: Function "Digital inputs"

Electrical connection

9.4.7 Digital outputs and output relays

Technical data

→ See page 31, chapter 4.3.



NOTE!

The digital output functions can be freely parameterised. → For output parameterisation, refer to page 99, chapter 10.

Factory setting

Clamp	Description	Function
DO1	Digital output 1	Boom locking
DO2	Digital output 2	Pulse after passage
DO3	Digital output 3	Signal light A
DO4	Digital output 4	Signal light B
NO1	Relay 1	Open
NO2	Relay 2	Closed
NO3	Relay 3	Error
NO4/NC4	Relay 4	Loop active A
NO5/NC5	Relay 5	Loop active B
NO6/NC6	Relay 6	Signal light C

Table 16: Factory settings "Digital outputs" and "Relay outputs"

Function	Description
Error	When the control unit recognises any "safety-relevant error" or "error", the output with this function is reactivated (Fail safe). → See page 157, chapter 13.3.
Warning	When the control unit recognises any "Warning", the output with this function is reactivated (Fail safe).
Closed	When the barrier is closed, the output with this function is active.
Open	When the barrier is open, the output with this function is active.
Closing	While the barrier closes, the output with this function is active.
Opening	While the barrier opens, the output with this function is active.
Boom angle	This function is used to set the upper and lower angles. When the barrier boom is within this angle range, the output with this function is active. When the barrier boom is outside of the angle range set, the output is inactive. The upper and lower angle can be set for values between 0° and 90°.
Pulse after passage ¹⁾	When a passage was detected, this output emits a counter pulse of 300 ms with this function. Passage is possible in either direction.
Sliding door pulse	This output is used to control a sliding gate. When the barrier is open, the output with this function emits a counter pulse of 300 ms with this function.

Electrical connection

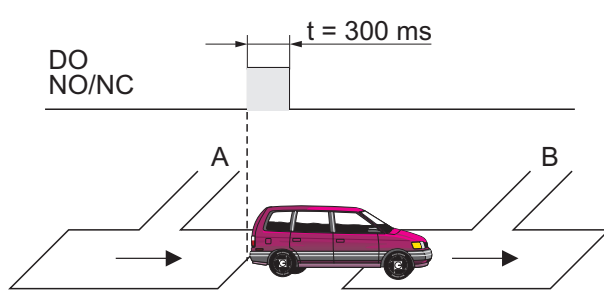
Function	Description
Boom contact FB (Boom contact feedback)	The barrier can optionally be equipped with a boom contact in the flange. When the boom contact triggers, the output with this function is deactivated (fail safe). The output is activated again once the boom contact is re-established and the boom is opened again entirely.
Boom locking	The barrier can optionally be equipped with a boom lock. This output serves control of the electro-mechanical boom lock at the end of the barrier boom. When the barrier is closed, the boom lock is activated via this output. If a signal is present for opening, the boom lock is removed first. The barrier opens with a short delay. The parameter "With boom locking" must be activated in the menu "Boom locking". → See page 136, chapter 10.11.3.
Parallel operation	This output can be used to operate two barriers synchronously. This output function must be activated via the menu "Master/Slave". → See page 131, chapter 10.10.11. → For information on parallel operation, see separate instructions.
Acknowledgment	This output is required for parallel operation. → For information on parallel operation, see separate instructions.
Signal light A	This output is used to control a signal light. The function of this output can be parameterised via the parameter "Signal light A", page 132, chapter 10.11.1.
Signal light B	This output is used to control a signal light. The function of this output can be parameterised via the parameter "Signal light B", page 132, chapter 10.11.1.
Signal light C	This output is used to control a signal light. The function of this output can be parameterised via the parameter "Signal light C", page 132, chapter 10.11.1.
Loop active A	When the induction loop A is busy, the output with this function is active.
Loop active B	When the induction loop B is busy, the output with this function is active.
Loop active pulse A ¹⁾	When a vehicle drives into loop A (rising flank), the output with this function emits an impulse.
Loop active pulse B ¹⁾	When a vehicle drives into loop B (rising flank), the output with this function emits an impulse.
Loop inactive pulse A ¹⁾	When a vehicle drives out of loop A (falling flank), the output with this function emits an impulse.
Loop inactive pulse B ¹⁾	When a vehicle drives out of loop B (falling flank), the output with this function emits an impulse.
Direction 1 Pls A => B ¹⁾	<p>The vehicle drives from direction A to B. When the vehicle leaves loop A in the direction of loop B, this output emits a counter impulse of 300 ms.</p>  <p style="text-align: right; font-size: small;">Mag00113</p>

Electrical connection

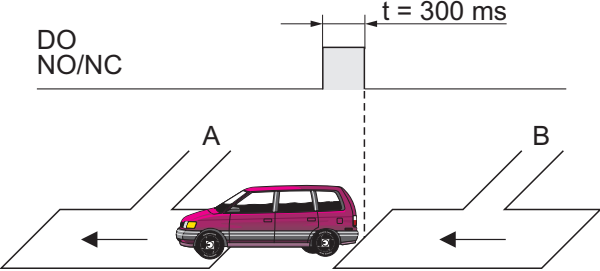
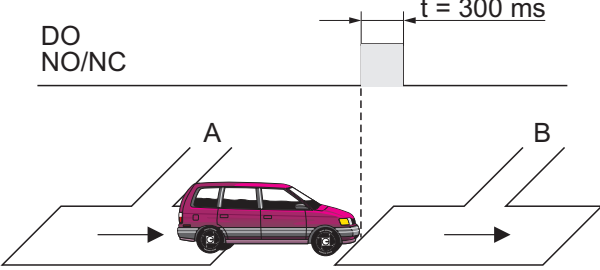
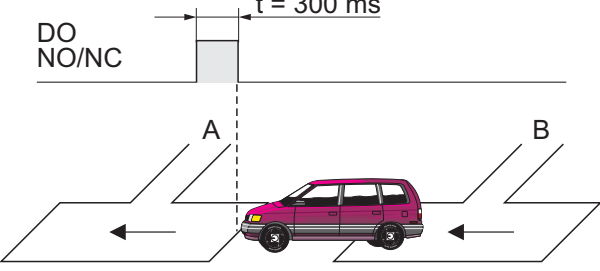
Function	Description
Direction 1 Pls B => A ¹⁾	<p>The vehicle drives from direction B to A. When the vehicle leaves loop B in the direction of loop A, this output emits a counter impulse of 300 ms.</p>  <p style="text-align: right; font-size: small;">Mag000114</p>
Direction 2 Pls A => B ¹⁾	<p>The vehicle drives from direction A to B. When the vehicle drives on loop A in the direction of loop B, this output emits a counter impulse of 300 ms.</p>  <p style="text-align: right; font-size: small;">Mag00115</p>
Direction 2 Pls B => A ¹⁾	<p>The vehicle drives from direction B to A. When the vehicle drives on loop B in the direction of loop A, this output emits a counter impulse of 300 ms.</p>  <p style="text-align: right; font-size: small;">Mag00116</p>

Electrical connection

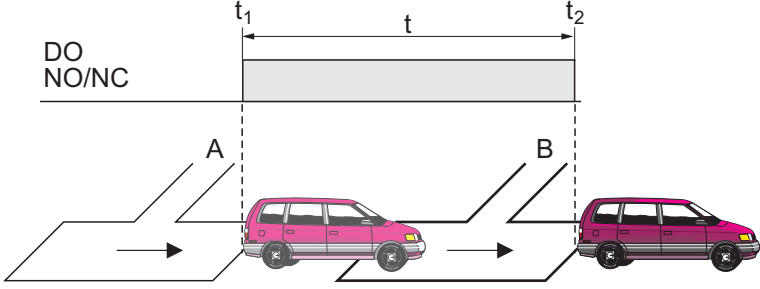
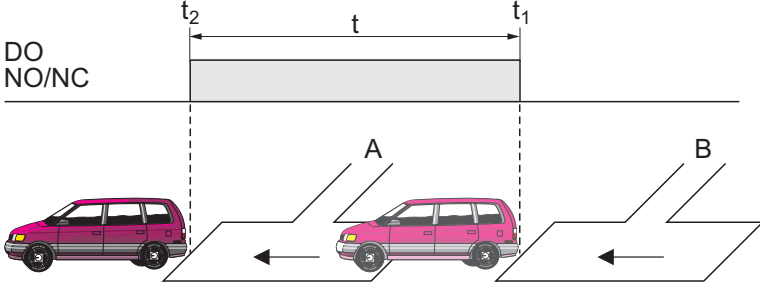
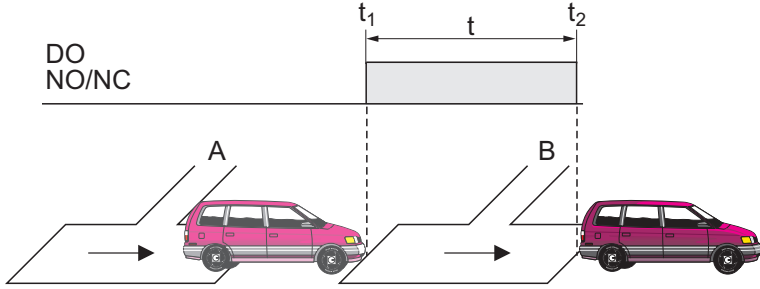
Function	Description
Direction 1 A => B ¹⁾	<p>The vehicle drives from direction A to B. When the vehicle leaves loop A, this output starts emitting a permanent signal. When the vehicle leaves loop B, this output stops the permanent signal. This function can be used, e.g. to control traffic lights.</p>  <p style="text-align: right; font-size: small;">Mag00117</p>
Direction 1 B => A ¹⁾	<p>The vehicle drives from direction B to A. When the vehicle leaves loop B, this output starts emitting a continuous signal. When the vehicle leaves loop A, this output stops the permanent signal. This function can be used, e.g. to control traffic lights.</p>  <p style="text-align: right; font-size: small;">Mag00118</p>
Direction 2 A => B ¹⁾	<p>The vehicle drives from direction A to B. When the vehicle enters loop B, this output starts emitting a continuous signal. When the vehicle leaves loop B, this output stops the permanent signal. This function can be used, e.g. to control traffic lights.</p>  <p style="text-align: right; font-size: small;">Mag00119</p>

Electrical connection

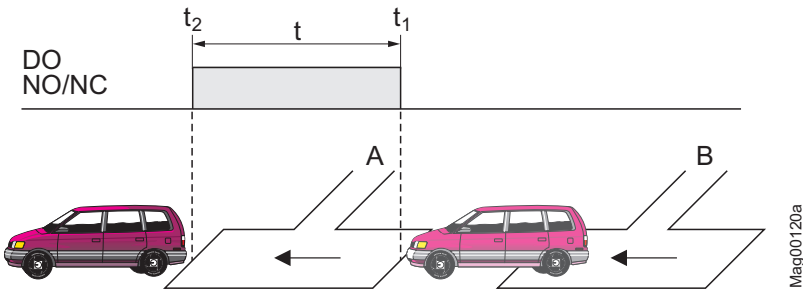
Function	Description
Direction 2 B => A ¹⁾	<p>The vehicle drives from direction B to A. When the vehicle enters loop A, this output starts emitting a continuous signal. When the vehicle leaves loop A, this output stops the permanent signal. This function can be used, e.g. to control traffic lights.</p> 
Module-Open prior ²⁾	This output function can be used to issue the command "Open high priority" of plug-in modules like "Ethernet", "Radio" or "RS485".
Module-Open ²⁾	This output function can be used to issue the command "Open" of plug-in modules like "Ethernet", "Radio" or "RS485".
Module-Close ²⁾	This output function can be used to issue the command "Close" of plug-in modules like "Ethernet", "Radio" or "RS485".

1) This function is only available with the plug-in module "Detector" plugged in.

2) This function is only available with the plug-in module "Ethernet", "Radio" or "RS485" plugged in.

Table 17: Function "Digital outputs" and "Output relay"

9.5 Checking the electrical connection

The following points have to be checked after the electrical installation of the barrier:



- Are the following electrical protective devices installed: lockable 2-pole main switch, circuit breaker and leakage current fault interrupter?
- Is the power cable connected to the terminal in compliance with chapter 9.3?
- Are the induction loops connected according to the wiring diagram?
- Are the safety light barriers connected according to the wiring diagram?
- Are the control lines connected according to wiring diagram?
- Have all barrier housing covers been properly assembled?

10 Parameterising control unit

10.1 Safety

→ See also safety notes on page 17, chapter 2.6 "Occupational safety and special dangers".

Improper parameterisation

 WARNING!	
	<p>Risk of injury by improper parameterisation of the control unit!</p> <p>Improper parameterisation of the control unit can lead to severe injuries!</p> <p>Therefore:</p> <ul style="list-style-type: none"> – The parameterisation of the control unit may only be carried out by qualified personnel or electricians. – The electrical connection of the signal generators to the IN1 to IN8 inputs must fit the parameterisation.

10.2 Control elements control unit

Control elements control unit MGC (Magnetic Gate Controller)

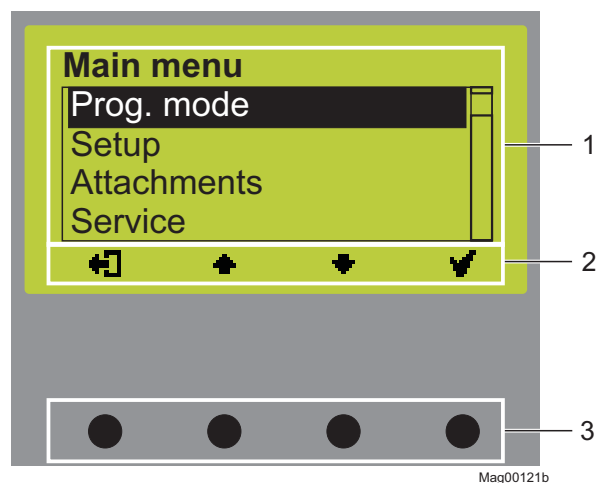

Fig. 44: Control unit elements MGC

- 1 Menu
- 2 Current function of the 4 control buttons
- 3 Control buttons

Parameterising control unit

10.3 Displays on the control unit

Example "Operational view"

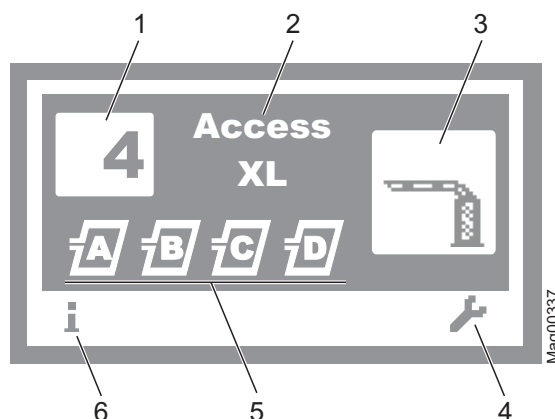

Fig. 45: Example "Operational view"

- 1 Programme mode, here programme mode 4
- 2 Barrier type, here type "Access XL"
- 3 Current state of the barrier, here barrier closed
- 4 Current function of the right control button, here calling menu "Main menu"
- 5 Current state of the induction loops
- 6 Current function of the left control button, here calling menu "Information"

Example "Screen change value"

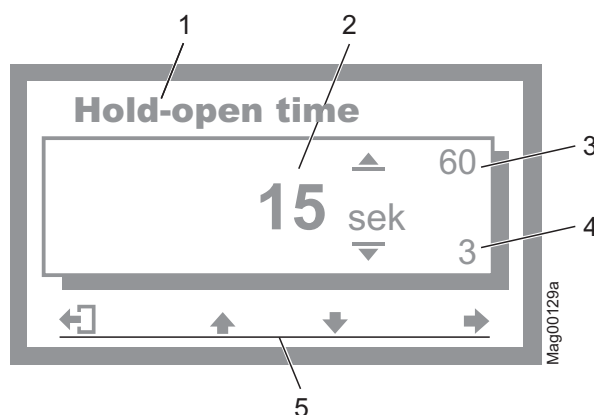

Fig. 46: Example "Screen Change value"

- 1 Parameter
- 2 Current value
- 3 Possible upper value
- 4 Possible lower value
- 5 Current functions control buttons

10.4 Symbols in the display

10.4.1 Control button functions

The control unit is equipped with 4 control buttons. The function of the control buttons change depending on the current view in the display. The current functions are displayed.













Symbols	Description
	<ul style="list-style-type: none"> ■ Call menu "Information". ■ Scroll menu "Information".
	Perform loop reconciliation
	<ul style="list-style-type: none"> ■ Call menu "Main menu" Make all settings in the menu "Main menu". ■ Menu "Information" → Menu "Detector": Perform reference of the induction loops.
	Leave current menu level. The next-higher menu level is displayed.
	<ul style="list-style-type: none"> ■ Call next-lower menu level. ■ Select desired option or desired value. When the desired option was selected, the symbol  is displayed.
	Option was selected but not yet stored
	<ul style="list-style-type: none"> ■ Within one menu level: Move cursor (market) upwards. ■ For setting value: Increase figure.
	<ul style="list-style-type: none"> ■ Within one menu level: Move cursor (market) downwards. ■ For setting value: Decrease figure.
	<ul style="list-style-type: none"> ■ Move cursor one position to the right. ■ Menu "Information" → Menu "Detector", for plug-in module "Detector (C-D)": Call view "Detector (C-D)" and switch between "Detector (A-B)" and "Detector (C-D)".
	Programme mode "Service": Manually open the barrier.
	Programme mode "Service": Manually close the barrier.
	<ul style="list-style-type: none"> ■ Delete error message. ■ When changing settings: Cancel changing process.

Table 18: Control button functions

Parameterising control unit

10.4.2 Current state of the barrier

The barrier can have the following states:









Symbols	Description
	Barrier boom closed.
	Barrier boom open.
	Barrier boom opens.
	Closing signal was recognised. Traffic lights active. Barrier closes in 5 seconds. Time for traffic light lead is counted down.
	Barrier boom closes.
	Monitoring unit used.
	Barrier boom position unknown. "Homing" active.
	Barrier boom stopped
	An error is present.

Table 19: Current state of the barrier

10.4.3 Current programme mode



Symbols	Description
	Current programme mode, here programme mode 4 → For description of programme modes, refer to page 106, chapter 10.7.
	Programme mode "Service" → For description of programme mode "Service", refer to page 116, chapter 10.7.7.

Table 20: Current programme mode

10.4.4 Current state of the induction loops

The induction loops can have the following states:





Symbols	Description
	Loop A and B connected. The induction loop function is OK. If the icon flashes, the loop is occupied. If another "detector" plug-in module is connected, these induction loops are marked "C" and "D".
	The induction loop assumes the function of the safety loop. → See page 137, chapter 10.15.
	Reference is performed.
	Induction loop deactivated.
	Induction loop defective.

Table 21: Current state of the induction loops

10.4.5 Further symbols



Symbols	Description
	Wrong password entered. Access denied.
	Reset values to factory settings. Enter the password "0000" for this.

Table 22: Further symbols













Parameterising control unit

10.5 Parameterising options

→ Menu setup, refer to page 177.





















→ Programme modes overview, refer to page 106.

Example: Select programme mode

1. The operating view is displayed. → See page 100, Fig. 45.
2. Press right control button .
3. The "Main menu" menu is displayed.
4. The "Programme mode" menu is highlighted with a dark background and therefore selected. If required, select the "Programme mode" menu with the two middle buttons  , .
5. Confirm selection with the right control button .
6. A list with the possible programme modes is displayed.
7. Select the desired programme mode with the two middle buttons  , .
8. Use the right button  to select the new programming mode. Your selection is marked with the symbol .
9. Use the left button  to leave the "Programme mode" menu.
10. The safety prompt "Save changes?" appears.
 - If the changes are to be saved, press the right button  . The new programme mode is activated.
 - If the changes are not to be saved, press the left button  . The previous programme mode remains active.
11. The "Main menu" menu is displayed.
12. Use the left button  to leave the "Main menu" menu. The operating view is displayed.

10.6 Parameterising values

Example: Change hold-open time

1. The operating view is displayed. → See page 100, Fig. 45.
2. Press right control button .
3. The "Main menu" menu is displayed.
4. Select the menu "Setup" with the two middle buttons , .
5. Confirm selection with the right control button .
6. Select the menu "Delays" with the two middle buttons , .
7. Press right control button .
8. The "Hold-open time" parameter is highlighted with a dark background and therefore selected. If required, select the "Hold-open time" parameter with the two middle buttons , .
9. Press right control button .
10. The current hold-open time value is displayed. The cursor flashes on the first digit.
11. Use the middle buttons ,  to set the desired digit.
12. Use the right button  to move the cursor to the right.
13. The cursor flashes on the second digit.
14. Use the middle buttons ,  to set the desired digit.
15. Press the right button .
16. Use the left button  to leave the "Hold-open time" parameter.
17. The safety prompt "Save changes?" appears.
 - If the changes are to be saved, press the right button . The new hold-open time is activated.
 - If the changes are not to be saved, press the left button .
18. The "Delays" menu is displayed.
19. Press the left button  repeatedly until the operating view is displayed again.

Parameterising control unit

10.7 Select programme mode

8 programme modes and the service mode are available for the MHTM™ MicroDrive barriers.

Programme modes 1 to 4 are manual modes. In the manual modes, the barrier must be closed manually after a drive through.

Programme modes 5 to 8 are automatic modes. In the automatic modes, the barrier closes again automatically after a vehicle drives through.

Programme	Description
1	Maintained contact
2	Deadman
3	Pulse control (bistable)
4	Two-Pulse control (Open/Closed button) (Factory setting)
5	Automatic (5): with hold-open time
6	Automatic (6): with hold-open time and decoupling of the opening loop at drive through in the opposite direction
7	Automatic (7): without hold-open time
8	Automatic (8) without hold-open time and decoupling of the opening loop at drive through in the opposite direction
	Service

Table 23: Programme modes

Another programme mode can be selected pursuant to chapter 10.5, page 104.



NOTE!

For reasons of safety, the first barrier boom motion after programme mode change is performed at slow speed.

10.7.1 Mode 1: Maintained contact

Typical application

This mode is suitable, e.g. for parallel operation of two barriers.
→ See page 131, chapter 10.10.11 "Master/Slave".

Function

The barrier is controlled only by one switch.
When the switch is closed, the barrier closes. When the switch is opened, the barrier opens.

Supported input functions

Input function	Signal type	Supported/ Not supported
Open low priority	–	Not supported
Open low priority with vend count	–	Not supported
Open high priority (priority 1)	Impulse signal	Supported
Opening loop	–	Not supported
Close (priority 2)	Permanent signal	Supported

Table 24: Supported input functions "Maintained contact"

→ See page 91, chapter 9.4.6 "Digital inputs".

Parameterising control unit

10.7.2 Mode 2: Deadman

Typical application

This mode is suitable for barriers on parking places, factory premises, etc. The barrier must be operated by a person.

Function

The barrier is operated by two buttons.

For opening the barrier, the button "open" must be pressed until the barrier is open all the way. For closing the barrier the button "close" must be pressed until the barrier is closed.

If no button is pressed, the barrier stops. If the "close" button is then pressed, the barrier opens completely first for safety reasons and then closes.

If the closing process is interrupted, only opening will be possible. A signal at the "Close" input would in this case open the barrier. If the "Close" signal is removed, the opening process is interrupted. If there is an impulse at the "Open high priority" input, the barrier opens completely.

Supported input functions

Input function	Signal type	Supported/ Not supported
Open low priority (priority 3)	Permanent signal	Supported
Open low priority with vend count	–	Not supported
Open high priority (priority 1)	Impulse signal	Supported
Opening loop	–	Not supported
Close (priority 2)	Permanent signal	Supported

Table 25: Supported input functions "Deadman"

→ See page 91, chapter 9.4.6 "Digital inputs".

10.7.3 Mode 3: Pulse control (bistable)

Typical application

This mode is suitable for barriers on factory premises, etc. that are little frequented by vehicles. The signal generator may be, e.g. a wireless button. The barrier must be operated by a person.

Function

The barrier is opened and closed by one command unit (pulse repetition). Every impulse changes the barrier's movement direction. The impulse must be present between 100 and 300 ms.

- 1. Signal: barrier opens
- 2. Signal: barrier closes
- 3. Signal: barrier opens

etc.

If another impulse is given during closing, the barrier opens. If another impulse is given during opening, the barrier opens completely and closes afterwards for reasons of safety.

Supported input functions

Input function	Signal type	Supported/ Not supported
Open low priority (opening and closing alternatingly), (priority 2)	Impulse or permanent signal	Supported
Open low priority with vend count	–	Not supported
Open high priority (priority 1)	Impulse or permanent signal	Supported
Opening loop	–	Not supported
Close	–	Not supported

Table 26: Supported input functions "Pulse control"

→ See page 91, chapter 9.4.6 "Digital inputs".

Parameterising control unit

10.7.4 Mode 4: Two-pulse control

Typical application

This mode is suitable for barriers on factory premises, etc. that are often frequented by vehicles. The barrier must be operated by a person.

Function

The barrier is opened and closed completely via two separate command units (signal). One impulse on the respective input is sufficient for opening or closing. The impulse must be present between 100 and 300 ms.

The input function "Open high priority" is superordinated to the input function "Close". This means that while a closing signal is applied, the barrier can be opened by the signal "Open high priority". When the opening signal is removed, the barrier closes again at once after opening completely.

Supported input functions

Input function	Signal type	Supported/ Not supported
Open low priority	Impulse or permanent signal	Supported
Open low priority with vend count	Impulse signal	Supported
Open high priority	Impulse or permanent signal	Supported
Opening loop	–	Not supported
Close	Impulse or permanent signal	Supported

Table 27: Supported input functions "Two-Pulse control"

→ See page 91, chapter 9.4.6 "Digital inputs".

10.7.5 Automatic Modes 5 to 8: Drive direction 1 – overview and differences

The automatic modes differ in their functions in drive direction 1 "Safety loop → Opening loop".

In drive direction 2 "Opening loop → Safety loop", the automatic modes are identical. → See page 115, chapter 10.7.6.

Drive direction 1: "Safety loop → Opening loop"

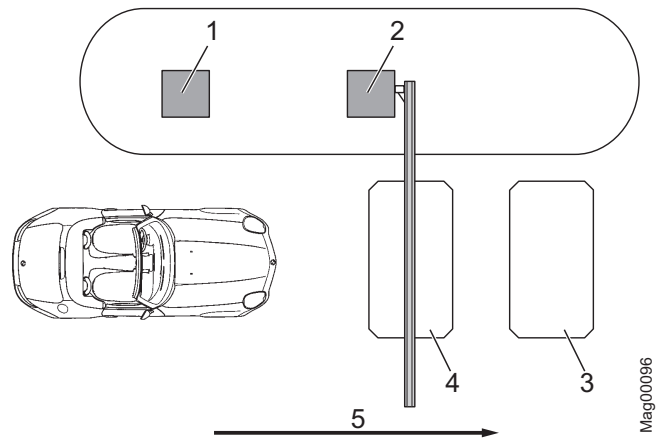

Fig. 47: Programme modes 5 to 8, Passage in direction 1

- 1 Remote control, card reader, coin acceptor, etc.
- 2 Barrier
- 3 Opening loop
- 4 Safety loop
- 5 Passage in direction 1

Programme mode	Hold-open time	Function Opening loop	Closing time drive backwards	Closing time without drive through
Automatic (5)	With hold-open time	The opening loop here acts as an extended safety loop.	If a vehicle drives onto the safety loop and leaves it again backwards, the barrier closes.	Barrier closes after the end of the opening time or at a closing signal.
Automatic (6)		The opening loop does not act as an extended safety loop here.		
Automatic (7)	Without hold-open time	The opening loop here acts as an extended safety loop.		Barrier closes after drive-through of the next vehicle or after the closing signal.
Automatic (8)		The opening loop does not act as an extended safety loop here.		

Table 28: Differences of automatic programme modes 5 to 8, direction 1

Parameterising control unit

Mode 5: Automatic (5)

Typical application

This mode is suitable for the automatic operation of a barrier, e.g. with card readers, remote control, coin acceptors and induction loops or light barriers. Passage of the barrier is possible in either direction.

Function

The barrier is opened from direction 1 "Safety loop → Opening loop" with an impulse at the "Open low priority" impulse, e.g. with a card reader or coin acceptor. The hold-open time that was set is also started.

When the vehicle leaves the safety loop, the hold-open time is deleted.

The barrier closes in the following cases:

- If the vehicle drives over both loops in direction 1, the barrier closes as soon as the vehicle leaves the opening loop. The opening loop here acts as an extended safety loop.
- If a vehicle drives onto the safety loop but leaves it again backwards, the barrier closes at once.
- If the vehicle drives over neither of the two loops, i.e. there is no drive through, the barrier closes after the end of the hold-open time.

→ For barriers with a safety light barrier but no safety loop installed, see page 131, chapter 10.10.10.

Mode 6: Automatic (6)

Typical application

This mode is suitable for the automatic operation of a barrier, e.g. with card readers, remote control, coin acceptors and induction loops or light barriers. Passage of the barrier is possible in either direction.

Function

The barrier is opened from direction 1 "Safety loop → Opening loop" with an impulse at the "Open low priority" impulse, e.g. with a card reader or coin acceptor. The hold-open time that was set is also started.

When the vehicle leaves the safety loop, the hold-open time is deleted.

The barrier closes in the following cases:

- If the vehicle drives over both loops in direction 1 "Safety loop → Opening loop", the barrier closes as soon as the vehicle leaves the safety loop. The opening loop here does not act as an extended safety loop.
- If a vehicle drives onto the safety loop but leaves it again backwards, the barrier closes.
- If the vehicle drives over neither of the two loops, i.e. there is no drive through, the barrier closes after the end of the hold-open time.

→ For barriers with a safety light barrier but no safety loop installed, see page 131, chapter 10.10.10.

Mode 7: Automatic (7)

Typical application

This mode is suitable for the automatic operation of a barrier, e.g. with ticket vending machines with internal logic. Passage of the barrier is possible in either direction.

Function

From direction 1 "Safety loop → Opening loop", the barrier is opened by an opening signal at one of the digital opening inputs. Hold-open time is not active in this mode.

The barrier closes in the following cases:

- If the vehicle drives over both loops in direction 1, the barrier closes as soon as the vehicle leaves the opening loop. The opening loop here acts as an extended safety loop.
- If a vehicle drives onto the safety loop but leaves it again backwards, the barrier closes.
- If the vehicle does not drive onto any of the two loops, the barrier remains open until a vehicle drives through or a closing signal is given.

→ For barriers with a safety light barrier but no safety loop installed, see page 131, chapter 10.10.10.

Mode 8: Automatic (8)

Typical application

This mode is suitable for the automatic operation of a barrier, e.g. with ticket vending machines with internal logic. Passage of the barrier is possible in either direction.

Parameterising control unit

Function

From direction 1 "Safety loop → Opening loop", the barrier is opened by an opening signal at one of the digital opening inputs. Hold-open time is not active in this mode.

The barrier closes in the following cases:

- If the vehicle drives over both loops in direction 1 "Safety loop → Opening loop", the barrier closes as soon as the vehicle leaves the safety loop. The opening loop here does not act as an extended safety loop.
- If a vehicle drives onto the safety loop but leaves it again backwards, the barrier closes.
- If the vehicle does not drive onto any of the two loops, the barrier remains open until a vehicle drives through or a closing signal is given.

→ For barriers with a safety light barrier but no safety loop installed, see page 131, chapter 10.10.10.

Modes 5 to 8: Automatic (5) to (8) – supported input functions

Input function	Signal type	Supported/ Not supported
Open low priority	Impulse or permanent signal	Supported
Open low priority with vend count	Impulse signal	Supported
Open high priority	Impulse or permanent signal	Supported
Opening loop	–	Supported
Close	Impulse or permanent signal	Supported

Table 29: Supported input functions "Automatic (5) to (8)"

→ See page 91, chapter 9.4.6 "Digital inputs".

10.7.6 Automatic Modes 5 to 8: Drive direction 2

In drive direction 2 "Opening loop → safety loop", the automatic modes are identical.

Closing barrier boom – maximum distance of the induction loops

⚠ WARNING!	
	<p>Danger from closing boom!</p> <p>A closing boom may cause severe or lethal injury to persons, bicyclers, cabriolet drivers and motorcycle drivers!</p> <p>Therefore:</p> <ul style="list-style-type: none"> – The maximum distance between opening loop and safety loop must be not greater than max. 1 m. In direction 2 "Opening loop → Safety loop", the barrier closes as soon as the vehicle leaves the opening loop. This means, if the distance is too large, the barrier closes before the car has cleared the barrier. → See page 38, chapter 7.

Drive direction 2: "Opening loop → Safety loop"

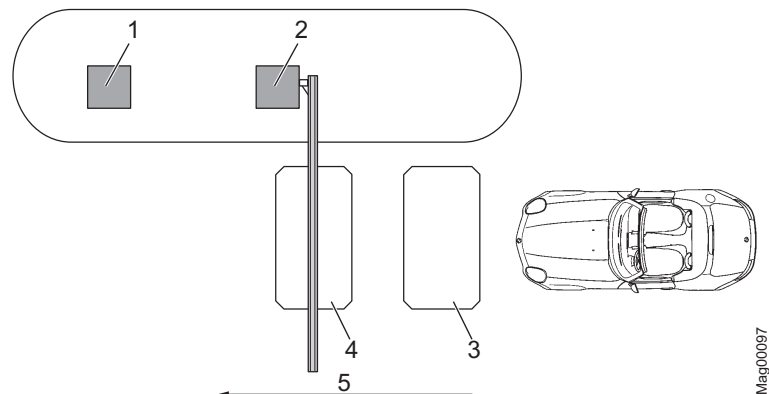

Fig. 48: Programme modes 5 to 8, Passage in direction 2

- 1 Remote control, card reader, coin acceptor, etc.
- 2 Barrier
- 3 Opening loop
- 4 Safety loop
- 5 Passage in direction 2

In direction 2, the opening loop is driven on first. The barrier opens. While the opening loop or safety loop is occupied, the barrier remains open. When the vehicle has left both loops, the barrier closes.

Hold-open time is not active in drive direction 2.

When the vehicle leaves the opening loop backwards, the barrier closes at once.

Parameterising control unit

10.7.7 Mode "Service"

In the "Service" mode, all opening and closing signals are ignored. The functions of safety devices like the safety loop or safety light barrier remain active for security reasons. This means that as soon as, e.g., the safety loop is occupied, the barrier cannot be closed.

Switch on Mode "Service"

Switch the "Service" switch for the "Service" mode. The LED lights red. The display backlighting flashes.

Switch off Mode "Service"

After the service work, the switch "Service" must be switched. The LED must light green.

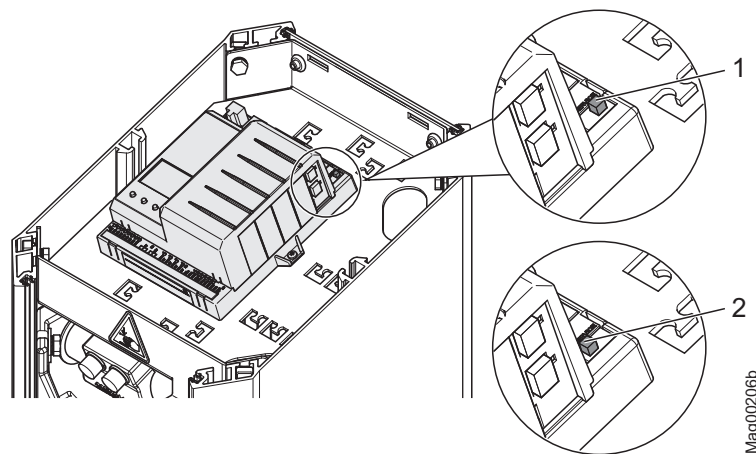



Fig. 49: Service switch

- 1 Mode "Service" on
- 2 Mode "Service" off

Button function

In the "Service" mode, you can control the motor with the two middle control buttons.

- Middle left button : Manually open the barrier.
- Middle right button : Manually close the barrier.



NOTE!

For reasons of safety, the first barrier boom motion after programme mode change is performed at slow speed.

10.8 Menu "Information" (i)

Call and navigate

1. The operating view is displayed. → See page 100, Fig. 45.
2. Press left control button **i**.
3. Use the left control button **i** to scroll within the menu.
4. The "Information" menu is can be left as follows:
 - Press the left control button **i** repeatedly until the operating view is displayed again or
 - Press right control button **+** control button.

Operating view → Information	
Parameters	Description
Error messages	Shows the currently pending errors. If no error messages are present, the menu is not displayed.
Inputs	Displays the current settings for the digital inputs IN1 to IN8
Outputs	Displays the current settings for the digital outputs DO1 to DO4 and the relay outputs NO1 to NO3 and NO/NC4 to NO/NC6.
Module info	Display of the software numbers (software #) and software versions (SW version) of the control unit and plugged-in plug-in modules.
Induction loops Detector (A-B), Detector (C-D)	Displays the current frequencies of the connected induction loops. The first plug-in module is displayed as "Detector (A-B)". The second plug-in module is displayed as "Detector (C-D)". The frequencies of induction loops A and B are displayed directly. To display the frequencies for the induction loops C and D, you have to press the button + . Use the button + you can switch the view between "Detector (A-B)" and "Detector (C-D)". → See page 137, chapter 10.15 "Menu detector 1 (A-B)".

Table 30: Menu "Information"

10.9 Programme mode

→ See page 106, chapter 10.7.

Parameterising control unit

10.10 Menu "Setup"

10.10.1 Barrier speed

Operating view → Main menu → Setup → Barrier speed	
Parameters	Description
Closing	<p>Select the closing speed for the barrier boom. The option "fast" corresponds to the barrier-specific speed (100 %).</p> <p>Options</p> <ul style="list-style-type: none"> ■ slow: approx. 50 % of the maximum speed ■ medium: approx. 70 % of the maximum speed ■ fast: maximum speed (barrier-specific speed) <p>Factory setting</p> <ul style="list-style-type: none"> ■ fast
Open	<p>Select the opening speed for the barrier boom. The option "fast" corresponds to the barrier-specific speed (100 %).</p> <p>Options</p> <ul style="list-style-type: none"> ■ slow: approx. 50 % of the maximum speed ■ medium: approx. 70 % of the maximum speed ■ fast: maximum speed (barrier-specific speed) <p>Factory setting</p> <ul style="list-style-type: none"> ■ fast

Table 31: Menu "Barrier speed"

10.10.2 Delays

Operating view → Main menu → Setup → Delays	
Parameters	Description
Hold-open time	<p>The parameter "Hold-open time" sets the hold-open time for the automatic programme modes 5 and 6.</p> <p>The hold-open time is started by an opening impulse by a control unit, such as a card reader. A passage should occur during the set hold-open time. If no passage occurs during the hold-open time, the barrier closes automatically. When the vehicle drives on the safety loop, the hold-open time is deleted.</p> <p>Setting range</p> <ul style="list-style-type: none"> ■ 3 to 60 s <p>Factory setting</p> <ul style="list-style-type: none"> ■ 30 s
Close delay	<p>The barrier only closes if the set time for the closing delay is over. The timer for closing delay is started with the closing signal. With this parameter, you can also set the "Lead time" in the "Signal light" menu.</p> <p>Setting range</p> <ul style="list-style-type: none"> ■ 0 to 15 s <p>Factory setting</p> <ul style="list-style-type: none"> ■ 0 s

Operating view → Main menu → Setup → Delays	
Parameters	Description
Light barrier delay	<p>The barrier only closes if the set time for the light barrier delay is over. The timer for light barrier delay is started with clearance of the light barrier.</p> <p>Setting range</p> <ul style="list-style-type: none"> ■ 0 to 15 s <p>Factory setting</p> <ul style="list-style-type: none"> ■ 5 s
Impact delay	<p>After the control unit has recognised that, e.g., a vehicle roof was hit by the closing barrier boom, the control unit tries to close the barrier again after the set impact delay. Impact is possible if, e.g., a user tries to drive through the barrier without permission.</p> <p>The following conditions must be met for the barrier to close after the end of the impact delay:</p> <ul style="list-style-type: none"> ■ In the "Impact Settings" menu, the parameter "Restart" must be set to "Automatic". ■ The safety devices, such as safety loop or safety light barrier must be clear. <p>→ Also see page 124, chapter 10.10.7, menu "Impact settings".</p> <p>Setting range</p> <ul style="list-style-type: none"> ■ 5 to 30 s <p>Factory setting</p> <ul style="list-style-type: none"> ■ 5 s

Table 32: Menu "Delays"

Parameterising control unit

10.10.3 Cut off angle

Operating view → Main menu → Setup → Cut off angle	
Parameters	Description
Safety loop close	<p>This parameter serves to ensure that a closed barrier can not be opened without authorisation.</p> <p>Where the barrier boom is below the set angle for "Safety loop close" during closing, signals of safety facilities like the safety loop or safety light barrier are ignored. I.e., the barrier closes completely below the angle set here.</p> <p>Setting range</p> <ul style="list-style-type: none"> ■ 1 to 40° <p>Factory setting</p> <ul style="list-style-type: none"> ■ 10°
Light barrier	<p>Where the barrier boom is below the set angle for "Light barrier" during closing, the light barrier is ignored. I.e., the barrier closes completely below the angle set here even if the light barrier is covered.</p> <p>Setting range</p> <ul style="list-style-type: none"> ■ 1 to 40° <p>Factory setting</p> <ul style="list-style-type: none"> ■ 10°
Impact detection	<p>Where the barrier boom is below the set angle for impact detection during closing, impact detection is deactivated. I.e., the barrier tries to close completely below the angle set here.</p> <p>Observe the length of the barrier boom when setting the angle. The barrier boom tip height at impact detection depends on the angle set and the barrier boom length.</p> <p>Setting range</p> <ul style="list-style-type: none"> ■ 1 to 40° <p>Factory setting</p> <ul style="list-style-type: none"> ■ 10°

Table 33: Menu "Cut off angle"

10.10.4 Inputs

→ See page 91, chapter 9.4.6.

10.10.5 Outputs

→ See page 94, chapter 9.4.7.

10.10.6 Vend count

Operating view → Main menu → Setup → Vend count	
Parameters	Description
Reset behaviour	<p>Use this parameter to set vend count reset behaviour. The function "Vend count" is available for programme modes 4 to 8. An internal vend count counts the impulses present at the input with the "Opening with vend count" function. The pulses are decremented only in driving direction 1 "Safety loop → Opening loop".</p> <p>Options</p> <ul style="list-style-type: none"> ■ no counter reset (without vend count reset) ■ Time-out The vend count is set to the value "0" if the vehicle does not pass the supervision device within the set hold-open time. ■ Reset on closing The vend count is set to value "0" when a closing signal is given. ■ Time-out/Reset on closing The vend count is set to the value "0" if the event "Time-out" or the event "Reset on closing" occurs. <p>Factory setting</p> <ul style="list-style-type: none"> ■ Time-out/Reset on closing
Counter	This parameter shows the current counter reading of the vend count.
Count open loop	<p>This function is sensible for systems where the opening loop is installed farther than one vehicle length away from the safety loop. When using this function, passage is permitted in one direction only.</p> <p>Once the function is activated, passages over the opening loop are counted as impulse. The direction is not considered when decrementing the impulses.</p> <p>Options</p> <ul style="list-style-type: none"> ■ inactive ■ active <p>Factory setting</p> <ul style="list-style-type: none"> ■ inactive

Table 34: Menu "Vend count"

Example vend count with programme mode "Automatic mode (5)"

This mode is suitable for the automatic operation of a barrier, e.g. with card readers, remote control, coin acceptors and induction loops or light barriers. The control units and the barrier have a larger distance from each other. Instead of a hold-open time, an internal vend count is incremented and decremented. Passage of the barrier is possible in either direction.



NOTE!

In systems where no opening loop is active or the parameter "Count open loops" is active, the impulses are decremented via the safety loop only.

Parameterising control unit

Drive direction 1: "Safety loop → Opening loop"

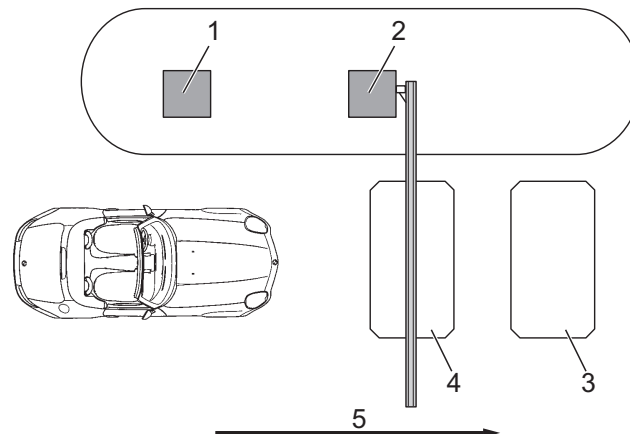

Fig. 50: Programme mode 5 with vend count,
Passage in direction 1

- 1 Remote control, card reader, coin acceptor, etc.
- 2 Barrier
- 3 Opening loop
- 4 Safety loop exit
- 5 Passage in direction 1

The barrier is opened from direction 1 "safety loop → opening loop" with an impulse at the "Open with vend count" impulse, e.g. with a card reader or coin checking device. At the same time, an internal vend count is incremented. For the parameter "Count open loops", the option "inactive" is set.

After passage of the safety loop and the opening loop, the vend count is decremented again. When the internal vend count reaches the value "0", the barrier is closed.

Additionally, the vend count is set to the value "0" and the barrier closed in the following cases, depending on the settings for the "Vend count" parameter:

- The vehicle does not drive over the supervision facility within the set hold-open time.
- A closing signal is assigned.

The barrier closes in the following cases:

- If the vehicle drives over both loops in direction 1, the barrier closes as soon as the vehicle leaves the opening loop. The opening loop here acts as an extended safety loop.
- If a vehicle drives onto the safety loop but leaves it again backwards, the hold-open time is deleted and the barrier closes.
- If the vehicle drives over neither of the two loops, i.e. there is no drive through, the barrier closes depending on setting of the "vend count" parameter.

Drive direction 2: "Opening loop → Safety loop"

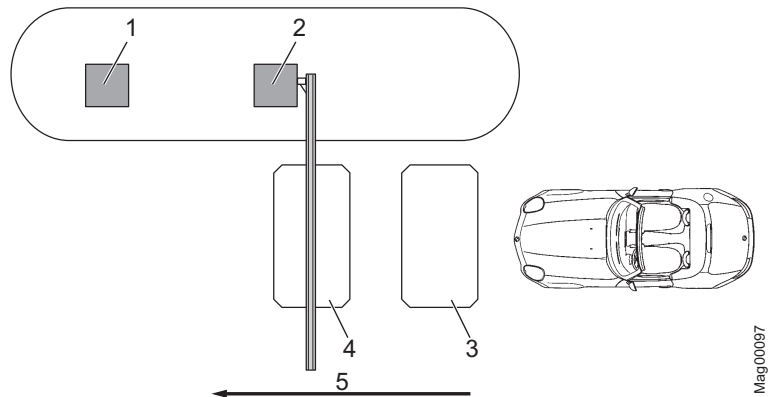

Mag00097

*Fig. 51: Programme mode 5 with impulse storage,
Passage in direction 2*

- 1 Remote control, card reader, coin acceptor, etc.
- 2 Barrier
- 3 Opening loop
- 4 Safety loop exit
- 5 Passage in direction 2

In direction 2, the opening loop is driven on first. The barrier opens. While the opening loop or safety loop is occupied, the barrier remains open. When the vehicle has left both loops will the barrier close.

From drive direction 2, vend count is not active.

When the vehicle leaves the opening loop backwards, the barrier closes at one.

Parameterising control unit

10.10.7 Impact settings

Operating view → Main menu → Setup → Impact settings	
Parameters	Description
Impact response	<p>Select the barrier boom's impact reaction if the control unit detects an impact. → Also see page 120, chapter 10.10.3, parameter "Impact detection".</p> <p>Select the barrier boom's impact reaction if the control unit detects an impact. This setting relates to the impact detection while the barrier boom closes. If an impact is recognised during opening, the barrier boom is stopped.</p> <p>Options</p> <ul style="list-style-type: none"> ■ Open After impact detection, the barrier boom is opened completely. ■ Stop After impact detection, the barrier boom's closing movement is stopped. ■ Safe stop After impact detection, the barrier boom's closing movement is first stopped and then slightly opened. <p>Factory setting</p> <ul style="list-style-type: none"> ■ Open
Impact delay	<p>After the control unit has recognised that, e.g., a vehicle roof was hit by the closing barrier boom, the control unit tries to close the barrier again after the set impact delay. Impact is possible if, e.g., a user tries to drive through the barrier without permission.</p> <p>The following conditions must be met for the barrier to close after the end of the impact delay:</p> <ul style="list-style-type: none"> ■ In the "Restart" parameter, the option must be set to "Automatic". ■ The safety devices, such as safety loop or safety light barrier, must be clear. <p>This parameter corresponds to the parameter "Impact delay" in the "Delays" menu.</p> <p>Setting range</p> <ul style="list-style-type: none"> ■ 5 to 30 s <p>Factory setting</p> <ul style="list-style-type: none"> ■ 5 s
Restart	<p>Select behaviour of the barrier after impact recognition.</p> <p>Options</p> <ul style="list-style-type: none"> ■ Automatic The barrier boom automatically completes the started movement after the impact delay has run. ■ Signal For the barrier boom to complete the started movement, the matching signal (open/close) must be applied. <p>Factory setting</p> <ul style="list-style-type: none"> ■ Signal

Table 35: Menu "Impact settings"

10.10.8 Start-up behaviour

Use this menu to select the start-up behaviour of the barrier according to the following events:

- after switching on voltage supply
- after return of voltage
- after reset

You can select between 8 options: The default setting is option "1".



NOTE!

The display messages "Waiting for passage" and "Waiting for release" can be confirmed with the left button of the control unit. Ensure that no persons or vehicles are present below the barrier boom. In operating modes 3 to 8, the barrier will close as soon as the message has been confirmed. In operating modes 1 and 2, a closing signal is still required after the message is confirmed.

Operating view → Main menu → Setup → Start-up behaviour	
Option	Description
1	<p>Reference run In this option, the barrier initially performs a reference run. This means that the barrier opens completely at low speed.</p> <p>Release signal No release signal is required to close the boom.</p> <p>Closing behaviour</p> <ul style="list-style-type: none"> ■ Programme modes 1 or 2: If a safety loop is installed, the barrier closes only after a vehicle has passed through and a permanent closing signal is pending. If only a safety light barrier is installed, no passage is required. The barrier closes at once when a permanent closing signal is applied. ■ Programme modes 3 to 8: If a safety loop is installed, the barrier closes when the first vehicle has driven through. If only a safety light barrier is installed, the barrier closes at once when the voltage returns.

Parameterising control unit

Operating view → Main menu → Setup → Start-up behaviour	
Option	Description
2	<p>Reference run In this option, the barrier initially performs a reference run. This means that the barrier opens completely at low speed.</p> <p>Release signal A release signal must be applied for the barrier to be ready for closing. The release signal can be applied even before the voltage returns. The release signal can be given by an external closing signal or by pushing the left operating button at the control unit.</p> <p>Closing behaviour</p> <ul style="list-style-type: none"> ■ Programme modes 1 or 2: If a safety loop is installed, the barrier closes only after a vehicle has passed through and a permanent closing signal is pending. If only a safety light barrier is installed, no passage is required. The barrier closes at once when a permanent closing signal is applied. ■ Programme modes 3 to 8: If a safety loop is installed, the barrier closes when the first vehicle has driven through. If only a safety light barrier is installed, the barrier closes at once when the voltage returns.
3	<p>Reference run In this option, the barrier initially performs a reference run. This means that the barrier opens completely at low speed.</p> <p>Release signal A release signal must be applied for the barrier to be ready for closing. If the release signal is applied before return of voltage, the release signal is ineffective. In this case, the release signal must be revoked and applied again after the barrier opens. The release signal can be given by an external closing signal or by pushing the left operating button at the control unit.</p> <p>Closing behaviour</p> <ul style="list-style-type: none"> ■ Programme modes 1 or 2: If a safety loop is installed, the barrier closes only after a vehicle has passed through and a permanent closing signal is pending. If only a safety light barrier is installed, no passage is required. The barrier closes at once when a permanent closing signal is applied. ■ Programme modes 3 to 8: If a safety loop is installed, the barrier closes only after the first vehicle has driven through. If only a safety light barrier is installed, the barrier closes at once when the voltage returns.

Operating view → Main menu → Setup → Start-up behaviour

Option	Description
4	<p>Reference run In this option, the barrier boom stops initially. The barrier will only carry out a reference run after a release signal.</p> <p>Release signal A release signal must be applied for the barrier to carry out a reference run. If the release signal is applied before return of voltage, the release signal is ineffective. In this case, the release signal must be revoked and applied again after the barrier opens. The release signal can be given by an external closing signal or by pushing the left operating button at the control unit.</p> <p>Closing behaviour</p> <ul style="list-style-type: none"> ■ Programme modes 1 or 2: If a safety loop is installed, the barrier closes only after a vehicle has passed through and a permanent closing signal is pending. If only a safety light barrier is installed, no passage is required. The barrier closes at once when a permanent closing signal is applied. ■ Programme modes 3 to 8: If a safety loop is installed, the barrier closes only after the first vehicle has driven through. If only a safety light barrier is installed, the barrier closes at once when the voltage returns.
5	<p>Reference run In this option, the barrier boom stops initially. The barrier will only carry out a reference run after a release signal.</p> <p>Release signal A release signal must be applied for the barrier to carry out a reference run. The release signal can be applied even before the voltage returns. The release signal can be given by an external closing signal or by pushing the left operating button at the control unit.</p> <p>Closing behaviour</p> <ul style="list-style-type: none"> ■ Programme modes 1 or 2: If a safety loop is installed, the barrier closes only after a vehicle has passed through and a permanent closing signal is pending. If only a safety light barrier is installed, no passage is required. The barrier closes at once when a permanent closing signal is applied. ■ Programme modes 3 to 8: If a safety loop is installed, the barrier closes only after the first vehicle has driven through. If only a safety light barrier is installed, the barrier closes at once when the voltage returns.

Parameterising control unit

Operating view → Main menu → Setup → Start-up behaviour	
Option	Description
6	<p>Reference run In this option, the barrier boom stops initially.</p> <p>Release signal The barrier carries out a reference run after the left operating button on the control unit is pressed.</p> <p>Closing behaviour</p> <ul style="list-style-type: none"> ■ Programme modes 1 or 2: The barrier closes at once when a permanent closing signal is applied. ■ Programme modes 3 to 8: The barrier closes at once after the barrier reference run.
7	<p>Reference run In this option, the barrier initially performs a reference run. This means that the barrier opens at low speed.</p> <p>Release signal No release signal is required to close the boom.</p> <p>Closing behaviour</p> <ul style="list-style-type: none"> ■ Programme modes 1 or 2: The barrier closes at once when a permanent closing signal is applied. ■ Programme modes 3 to 8: If a safety loop is installed, the barrier closes only after the first vehicle has driven through or after closing. If only a safety light barrier is installed, the barrier closes at once when the voltage returns. <p> WARNING! Danger of injury from closing boom!</p> <ul style="list-style-type: none"> ■ Sight contact to the barrier is required when the voltage is switched on again. ■ No vehicles and persons must stand below the barrier when the closing signal is given.

Operating view → Main menu → Setup → Start-up behaviour	
Option	Description
8	<p>Reference run In this option, the barrier initially performs a reference run. This means that the barrier opens at low speed.</p> <p>Release signal No release signal is required to close the boom.</p> <p>Closing behaviour</p> <ul style="list-style-type: none"> ■ Programme modes 1 or 2: The barrier closes at once when a permanent closing signal is applied. ■ Programme modes 3 to 8: Barrier closes at once. <p> WARNING! Danger of injury from closing boom!</p> <ul style="list-style-type: none"> ■ Sight contact to the barrier is required when the voltage is switched on again. ■ No vehicles and persons must stand below the barrier when the closing signal is given.

Table 36: Menu "Start-up behaviour"

Parameterising control unit

10.10.9 Power failure

Operating View → Main Menu → Setup → Power failure	
Parameters	Description
Power failure	<p>This parameter sets whether the barrier boom opens at power outage or opens or closes depending on the barrier boom position. The balancing springs must be set according to the selected option. → See page 72, chapter 8.13.</p> <p>Options</p> <ul style="list-style-type: none"> ■ Unlocked <p>With this option, the lever system of the closed barrier is unlocked; the barrier remains closed. The boom can be opened manually. If the boom angle is less than approx. 30°, the boom will close. If the barrier boom is above an angle of approx. 35°, the barrier boom opens. The balancing springs in the lever system must be set accordingly.</p> ■ Open <p>In this option, the barrier boom opens at power outage. The barrier boom is moved to the locked end position with the present residual energy of the mains unit and completely opened by the balancer springs of the lever system. The balancing springs must be set correctly and the barrier boom must not be kept in the closed position by external influence.</p> ■ Locked <p>For this option, the barrier boom behaviour depends on the barrier boom position at power outage. When the barrier is closed, it remains closed and the lever system remains locked. Manual opening of the barrier is not possible or requires considerable application of force. If the barrier boom is below an angle of approx. 30°, the barrier boom closes. If the barrier boom is above an angle of approx. 35°, the barrier boom opens. The balancing springs in the lever system must be set accordingly.</p> <p>Factory setting</p> <ul style="list-style-type: none"> ■ Unlocked

Table 37: Menu "Power failure"

10.10.10 Closure by light barrier

Operating view → Main menu → Setup → Closure by light barrier	
Parameters	Description
Closure by light barrier	<p>Use this parameter to select the closing behaviour for barriers with only one safety light barrier installed.</p> <p>If a safety loop is installed, the barrier closes only after the first vehicle has driven through in the automatic programme modes 5 to 8. If only a safety light barrier is installed, the barrier will not close automatically after the first vehicle has driven through in the automatic programme modes 5 to 8.</p> <p>Options</p> <ul style="list-style-type: none"> ■ inactive In programme modes 5 and 6, the barrier only closes if either a closing signal is applied or the hold-open time has passed. In programme modes 7 and 8, the barrier only closes when a closing signal is applied. ■ active In programme modes 5 to 8, the barrier closes at once when a vehicle drives through the safety light barrier and after passage of the set time for the parameter "Light barrier delay". → See page 119, chapter 10.10.2. <p>Factory setting</p> <ul style="list-style-type: none"> ■ inactive

Table 38: Menu "Closure by light barrier"

10.10.11 Master/Slave

Operating view → Main Menu → Setup → Master/Slave	
Parameters	Description
Master/Slave	<p>Activate and deactivate "Parallel operation" function. By activating the master/slave function, the corresponding inputs and outputs are automatically converted. → For information on parallel operation, see separate instructions.</p> <p>Options</p> <ul style="list-style-type: none"> ■ inactive ■ active <p>Factory setting</p> <ul style="list-style-type: none"> ■ inactive

Table 39: Menu "Master/Slave"

Parameterising control unit

10.10.12 Menu "Language"

Operating view → Main menu → Setup → Language	
Parameters	Description
Language	Select menu language Options <ul style="list-style-type: none"> ■ German ■ English ■ French ■ Spanish ■ Italian ■ Portuguese

Table 40: Menu "Language"

10.11 Menu "Attachments"

10.11.1 Signal light

The parameters "Signal mode A", "Signal mode B" and "Signal mode C" can be used to parameterise the function for the outputs "Signal light A", "Signal light B" and "Signal light C".

→ See page 94, Table 17.

You can connect three signal lights.

If you want to control light strips via the MAGNETIC control unit, you need to select the "Illumination strip red" option for "Signal Mode A" and "Illumination strip green" for "Signal Mode B".

Operating view → Main menu → Attachments → Signal light	
Parameters	Description
Signal mode A (continued on next page)	Select function for output "Signal light A". The parameter "lead time" can be used to parameterise the warning lamp so that it already lights up red or flashes before closing. The lead time is the time between the closing signal and commencement of the closing procedure. Options <ul style="list-style-type: none"> ■ Traffic light (permanent signal for red/green signal lights): <ul style="list-style-type: none"> ■ Barrier closed: Traffic light red ■ Barrier opens: Traffic light red ■ Barrier open (upper end position): Traffic light off ■ Barrier closes (without lead time)/closing time (with lead time): Traffic light red

Operating view → Main menu → Attachments → Signal light	
Parameters	Description
Signal mode A (continued)	<ul style="list-style-type: none"> ■ Warning signal (connection of a visual or acoustic signal/ permanent signal before and during closing of the barrier): <ul style="list-style-type: none"> ■ Barrier closed: Warning signal off ■ Barrier opens: Warning signal off ■ Barrier open (upper end position): Warning signal off ■ Barrier closes (without lead time)/ closing time (with lead time): Warning signal red ■ Flashing light (flashing light connection/ flashing signal while the barrier opens or closes): <ul style="list-style-type: none"> ■ Barrier closed: Flashing light off ■ Barrier opens: Flashing light flashes at 2 Hz ■ Barrier open (upper end position): Flashing light off ■ Barrier closes (without lead time)/ closing time (with lead time): Flashing light flashes at 2 Hz ■ Boom illumination (boom illumination connection/ permanent flashing signal except when the barrier is open): <ul style="list-style-type: none"> ■ Barrier closed: Illumination flashes at 2 Hz ■ Barrier opens: Illumination flashes at 2 Hz ■ Barrier open (upper end position): Illumination off ■ Barrier closes (without lead time)/ closing time (with lead time): Illumination flashes at 2 Hz ■ Illumination strip red / Boom illumination / Flashing light <ul style="list-style-type: none"> ■ Barrier closed (lower end position): Red, permanent light ■ Barrier opens: Red flashes at 2 Hz ■ Barrier open (upper end position): Red off ■ Barrier closes (without lead time)/ closing time (with lead time): Red flashes at 2 Hz <p>Factory setting</p> <ul style="list-style-type: none"> ■ Illumination strip red
Signal mode B	<p>Select function for output "Signal light B".</p> <p>Options</p> <p>→ For the options "Traffic light", "Warning signal", "Flashing lights", "Boom illumination", see parameters "signal mode A".</p> <ul style="list-style-type: none"> ■ Illumination strip green <ul style="list-style-type: none"> ■ Barrier closed (lower end position): Green off ■ Barrier opens: Green off ■ Barrier open (upper end position): Green, permanent light ■ Barrier closes (without lead time)/ closing time (with lead time): Green off <p>Factory setting</p> <ul style="list-style-type: none"> ■ Illumination strip green

Parameterising control unit

Operating view → Main menu → Attachments → Signal light	
Parameters	Description
Signal mode C	<p>Select function for output "Signal light C".</p> <p>Options</p> <ul style="list-style-type: none"> ■ Traffic light (permanent signal for red/green signal lights): <ul style="list-style-type: none"> ■ Barrier closed: Traffic light red ■ Barrier opens: Traffic light red ■ Barrier open (upper end position): Traffic light off ■ Barrier closes (without lead time)/ closing time (with lead time): Traffic light red ■ Warning signal (connection of a visual or acoustic signal/ permanent signal before and during closing of the barrier): <ul style="list-style-type: none"> ■ Barrier closed: Warning signal off ■ Barrier opens: Warning signal off ■ Barrier open (upper end position): Warning signal off ■ Barrier closes (without lead time)/ closing time (with lead time): Warning signal red <p>Factory setting</p> <ul style="list-style-type: none"> ■ Warning signal
Lead time	<p>In some application cases, it is required for reasons of safety that a warning signal for the following traffic lights up after before closing of the barrier. This warning signal must light up before the barrier closes. The warning signal is switched on with the closing signal and the lead time is started. The barrier closes only after the end of the set lead time With this parameter, you can also set the "Close delay" in the "Delays" menu.</p> <p>Setting range</p> <ul style="list-style-type: none"> ■ 0 to 15 s <p>Factory setting</p> <ul style="list-style-type: none"> ■ 0 s
Start event	<p>Select the start event from when on the signal lights should switch.</p> <p>Options</p> <ul style="list-style-type: none"> ■ Closing signal ■ Safety loop active The option "Safety loop active" is only sensible for the automatic programme modes 5 to 8. If an opening signal is pending, the signal lamps are not switched. <p>Factory setting</p> <ul style="list-style-type: none"> ■ Closing signal

Table 41: Menu "Signal light"

10.11.2 Boom contact settings

The barrier can optionally be equipped with a boom contact in the flange.

Operating view → Main menu → Attachments → Boom contact settings	
Parameters	Description
inactive/active	<p>The barrier can optionally be equipped with a boom contact in the flange. The function "Boom contact settings" is used to select the behaviour of the input function "Boom contact input" and the output function "Boom contact FB". The functions must be selected. → See page 91, chapter 9.4.6 and page 94, chapter 9.4.7.</p> <p>Options</p> <ul style="list-style-type: none"> ■ Inactive The "Boom contact" is inactive. If the output function "Boom contact FB" was selected, this output is deactivated once the boom contact triggers. The input "Boom contact input" has no function in this option. ■ Active The "Boom contact" is active. If "Boom contact FB" was selected for the output function, this output is deactivated once the boom contact triggers. If "Boom contact input" was selected for the input function, 24 V DC are pending at the input while the boom is resting in the flange. If the barrier boom is moved from its position, the +24 V DC are removed from the "Boom contact" input. The barrier moves into the "open" position. <p>Factory setting</p> <ul style="list-style-type: none"> ■ Inactive
Automatic closing	<p>Select signal for closing of the barrier boom after boom release.</p> <p>Options</p> <ul style="list-style-type: none"> ■ Automatic The barrier boom automatically closes after the end of the delay time. ■ Signal For the barrier boom to close, a signal must be applied to the input with the function "Close" or "Close low priority". <p>Factory setting</p> <ul style="list-style-type: none"> ■ Automatic
Closing delay	The parameter is not relevant for the barriers Access XL and Access XXL.

Table 42: Menu "Boom contact settings"

Parameterising control unit

10.11.3 Boom locking

The barrier can optionally be equipped with an electro-mechanical boom lock at the end of the barrier boom. When the barrier is closed, the boom locking is activated via the output function "Boom locking". If a signal is present for opening, the boom lock is released first. → See also page 94, digital output function "Boom locking".

Operating view → Main menu → Attachments → Boom locking	
Parameters	Description
Without boom locking	Boom locking not present
With boom locking	Boom locking present

Table 43: Menu "Boom locking"

10.12 Menu "Service"

This menu is only intended for MAGNETIC's service and only accessible with a password.

10.13 Menu "Information"

Operating view → Main menu → Information	
Parameters	Description
Serial No.	Displays the serial number of the control unit
Hardware Version	Displays the present hardware version
Software #	Display of the present software number
SW Version	Displays the present software version
Temperature	Displays the current temperature in the control unit

Table 44: Menu "Information"

10.14 Menu "Motor GW (Gateway)"

Operating View → Main Menu → Motor GW (Gateway)	
Parameters	Description
Software #	Displays the present software number
SW version	Displays the present software version
Motor temperature	Display of the current motor temperature
Motor-SW	Display of the present motor software

Table 45: Menu "Motor GW (Gateway)"

10.15 Menu "Detector 1 (A-B)"

This menu is used to reference the induction loops A and B.

Operating view → Main menu → Detector 1 (A-B)	
Parameters	Description
Recalibration	Start reference of the induction loops (activate)
Mode A	Select position and function of loop A. Options <ul style="list-style-type: none"> ■ Inactive Induction loop is not present or not relevant for evaluation. ■ Active The induction loop state is put on the output with function "Loop active". Internally, the induction loop condition is not used. ■ Safety loop The induction loop assumes the function of the safety loop. ■ Opening entry The induction loop assumes the function of the opening loop on the entry lane. ■ Open exit The induction loop assumes the function of the opening loop on the exit lane. ■ Presence entry The induction loop assumes the function of the presence loop on the entry lane. ■ Presence exit The induction loop assumes the function of the presence loop on the exit lane.
Mode B	Select position and function of loop B. → For description, see parameter "Mode A".
Sensitivity A	Set the response sensitivity of the induction loop A. The response sensitivity is divided into increments. Factory setting <ul style="list-style-type: none"> ■ 5 Setting range <ul style="list-style-type: none"> ■ 0 to 9
Sensitivity B	Set the response sensitivity of the induction loop B. → For description, see parameter "Sensitivity A".
Frequency settings	→ See page 138, Table 47.
Information	Displays information via the plug-in module "Detector 1 (A-B)". Here, the serial number (SerNo), hardware version, software # and software version and of the plug-in module are displayed.

Table 46: Menu "Detector 1 (A-B)"

Parameterising control unit

Operating view → Main menu → Detector 1 (A-B) → Frequency settings	
Parameters	Description
Freq. A	Displays the currently measured frequency for induction loop A
Freq. B	Displays the currently measured frequency for induction loop B
Frequ. Shift	<p>Interference influences, e.g. from external loop detectors or induction loops of barriers close by can influence the frequency of loops A and B. Use the parameter "Freq. Shift" to change the frequency values for loops A (channel A) and B (channel B) by approx. 10 % and thus reduce the influence of loops A and B.</p> <p>Options for channels A and B.</p> <ul style="list-style-type: none"> ■ High: high frequency value ■ Low: low frequency value
Ref value A	Displays the reference frequency for induction loop A
Ref value B	Displays the reference frequency for induction loop B

Table 47: Menu "Frequency settings"

10.15.1 Check the working frequency of the induction loops

1. The operating view is displayed. → See page 100, Fig. 45.
2. Press the left control button **i** repeatedly, until the menu "Detector 1 (A-B)" is displayed.

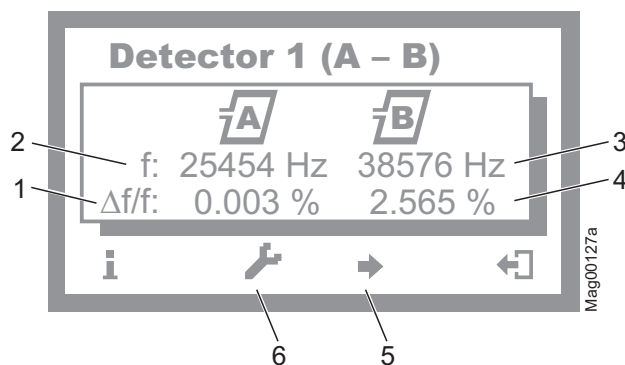

Fig. 52: Example "View – Menu Detector 1 (A-B)"

- 1 Relative frequency of induction loop A
 - 2 Currently measured frequency of induction loop A
 - 3 Currently measured frequency of induction loop B
 - 4 Relative frequency of induction loop B
 - 5 If another optional detector module is present: Switching between the two detector modules
 - 6 Recalibration of the induction loop
3. Use the right button **→** to leave the "Detector 1 (A-B)" menu. The operating view is displayed.

10.15.2 Reconciling and setting the operating frequency of the induction loop

Operating frequency requirements

The operating frequency must fulfil following requirements:

- When driving over the induction loop with a vehicle, a significant frequency increase must be measurable. Chose stage 5 or 6 for sensitivity. The relative frequency change ($\Delta f/f$) must be at least 0.1%. The higher the relative frequency increase, the higher the operating safety of the induction loop.
- The induction loops of a control unit operate alternating, and can therefore not affect each other. However, to avoid interferences by frequency coupling from external loop detectors or other control units in the direct proximity, a frequency clearance of at least 10000 Hz must be kept between them. For this, the menu "Freq. Shift" is used to set the frequency option to "Low" or "High", or to deactivate or adjust the induction loop coil number.

Reference working frequency via the menu "Information" (i)





















1. The operating view is displayed. → See page 100, Fig. 45.
2. Press left operating button **i**.
3. Press the left control button repeatedly, until the menu "Detector 1 (A-B)" is displayed. → See page 138, Fig. 52.
4. Press second operating button from the left **↵**.
5. The barrier is referenced. The loop symbols flash during reconciliation.
6. Check working frequencies. If required, perform settings like sensitivity, etc. in the menu "Detector 1 (A-B)" in the main menu.
7. Perform one of the following steps:
 - For a "Detector" plug-in module: Use the right button **↵** to leave the "Detector 1 (A-B)" menu. The operating view is displayed.
 - For two "Detector" plug-in modules: Press the third operating button from the left **↵**. The "Detector 2 (C-D)" menu is displayed.
8. The barrier is referenced. The loop symbols flash during reconciliation.
9. Check working frequencies. If required, perform settings like sensitivity, etc. in the menu "Detector 2 (C-D)" in the main menu.
10. Use the right button **↵** to leave the "Detector 2 (C-D)" menu. The operating view is displayed.

Parameterising control unit

Frequency value of the un-assigned induction loop unstable

If the frequency value of an induction loop is unstable, this induction loop is influenced by an induction loop of another barrier or an external detector. The detector channels do not influence each other.

Depending on the loop geometry and settings of the external detector, set the menu "Freq. Shift" to "Low" or "High".

1. The operating view is displayed. → See page 100, Fig. 45.
2. Press right operating button .
3. The "Main menu" menu is displayed.
4. Select the menu "Detector 1 (A-B)" with the two middle buttons , .
5. Confirm selection with the right control button .
6. The "Detector 1 (A-B)" menu is displayed.
7. Select the menu "Frequency settings" with the two middle buttons , .
8. Confirm selection with the right control button .
9. The "Frequency settings" menu is displayed.
10. Select the menu "Freq. Shift" with the two middle buttons , .
11. Confirm selection with the right control button .
12. The "Freq. Shift" menu is displayed.
13. Select the parameter "Channel A" or "Channel B" with the two middle buttons , .
14. Confirm selection with the right control button .
15. The corresponding menu is displayed.
16. Select the option "Low" or "High" for the respective channel with the two middle buttons , .
17. Use the right button  to select the option. Your selection is marked with the symbol .
18. Use the left button  to leave the menu.
19. The safety prompt "Save changes?" appears.
 - If the changes are to be saved, press the right button .
 - If the changes are not to be saved, press the left button .
20. Press the left button  repeatedly until the operating view is displayed again.
21. Test the operating frequencies.

For another plug-in module, the menu "Detector 2 (C-D)" is displayed in the main menu. Reconciliation is performed for the induction loops A and B.

10.16 Menu "Detector 2 (C-D)"

This menu is displayed if a second plug-in module with the function "Detector" was plugged into the control unit. This menu is used to reference the induction loops C and D.

The menu "Detector 2 (C-D)" corresponds to the menu "Detector 1 (A-D)". → See page 137, chapter 10.16.

10.17 Menu "Radio control FM"

The "Radio control FM" menu is displayed when the "Radio" plug-in module is plugged into one of the control unit slots.

The hand transmitters are available as 1-, 2- and 4-channel versions. With the multi-channel version, the corresponding number of barriers can be operated independently of each other with a hand transmitter.

If you want to operate the barrier via hand transmitter, a programme mode between 3 to 8 must be selected.

The barrier is opened or closed by pressing the button on the hand transmitter. After pressing the button on the hand transmitter, the hand transmitter number is indicated in the display.

A radio module can manage up to 100 hand transmitters using different codes.

Operating view → Main menu → Radio control FM	
Parameters	Description
Number of transmitter (Number of transm.)	Display of number of hand transmitters with which the barrier can be opened
Teach in remote control	Use this parameter to pair a hand transmitter with the radio module. Options <ul style="list-style-type: none"> ■ Open high priority The button is assigned to the function "Open high priority". ■ Opening The button is assigned to the function "Open". ■ Closing The button is assigned to the function "Close".
Delete remote control	Use this parameter to revoke a pairing between a hand transmitter and the radio module. Options <ul style="list-style-type: none"> ■ With remote control Dissolve pairing by pressing a button on the hand transmitter. ■ With number Dissolve pairing by entering the hand transmitter number. ■ Delete ALL Delete all hand transmitters. Password input is required for this.

Parameterising control unit

Operating view → Main menu → Radio control FM	
Parameters	Description
Information	Displays information via the plug-in module "Radio". Here, the hardware version, software version and serial number (SerNo) of the plug-in module are displayed.

Table 48: Menu "Radio control FM"

Set hand transmitter code

The hand transmitter code is set via DIP switches in the hand transmitter. We recommend changing the DIP switches' standard settings.

1. Open hand transmitter housing. For this, press the coloured pressure point while pulling up the upper housing part at the same time.
2. Change and document the DIP switches' settings.

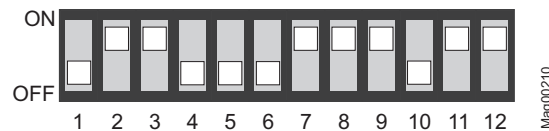





















Fig. 53: Example DIP switches settings

3. Close housing.

Teach in remote control example option "Close"

1. The operating view is displayed. → See page 100, Fig. 45.
2. Press right operating button .
3. The "Main menu" menu is displayed.
4. Select the menu "Radio control" with the two middle buttons , .
5. Confirm selection with the right control button .
6. Select the parameter "Teach in remote control" with the two middle buttons , .
7. Confirm selection with the right control button .
8. Select the parameter "Close" with the two middle buttons , .
9. The message "Press button" appears.
10. Press the button on the hand transmitter. For the 2-channel hand transmitter, the corresponding channel is paired with the radio module.
11. The message "Successful" appears on the display. The number for the parameter "Number of transmitter" is increased by one.
12. Press the left button  repeatedly until the operating view is displayed again.

Delete remote control

1. The operating view is displayed. → See page 100, Fig. 45.
2. Press right operating button .
3. The "Main menu" menu is displayed.
4. Select the menu "Radio control" with the two middle buttons , .
5. Confirm selection with the right control button .
6. Select the parameter "delete remote control" with the two middle buttons , .
7. Confirm selection with the right control button .
8. The options "with remote control" and "with number" are displayed.
9. Select an option with the two middle buttons , .
10. Confirm selection with the right control button .





Option "With remote control"

The option "With remote control" was selected

1. The message "press button" appears.
2. Press the button on the hand transmitter.
3. The message "Successful" appears. The number for the parameter "Number transmitter" is decreased by one.
4. Press the right button  repeatedly until the operating view is displayed again.

Option "With number"

The option "with number" was selected

1. Enter hand transmitter number.
2. Use the left button  to leave the menu.
3. The safety prompt "Save changes?" appears.
 - If the hand transmitter is to be deleted, press the right button .
 - If the hand transmitter is not to be deleted, press the left button .
4. The "Delete remote control" menu is displayed.
5. Press the left button  repeatedly until the operating view is displayed again.

Parameterising control unit

Option "Delete ALL"

The option "Delete ALL" was selected

1. Enter the service password.
2. Confirm input with the right control button .
3. The message "Successful" appears. All hand transmitters were deleted.











NOTE!

If a hand transmitter is deleted, the memory slot used is released. The sequence does not change by deletion. Teaching in new hand transmitters will first fill the gaps and only then continue numbering.

10.18 Factory settings

Reset parameters

This menu can be used to reset the parameters to factory settings.

1. The operating view is displayed. → See page 100, Fig. 45
2. Press right operating button .
3. The "Main menu" menu is displayed.
4. Select the menu "Factory Settings" with the two middle buttons , .
5. Confirm selection with the right control button .
6. Enter password "0 0 0 0".
7. Confirm password with the right control button .
8. The message "Reset to factory settings" appears.
9. Press right operating button .
10. The safety prompt "Save changes?" appears.
 - If the changes are to be saved, press the right button . The current settings are reset to factory settings. Restart is performed
 - If the changes are not to be saved, press the left button .
11. Press the left button  repeatedly until the operating view is displayed again.

11 Start-up and operation

11.1 Safety

→ See also safety notes on page 17, chapter 2.6 "Occupational safety and special dangers".

General

⚠ WARNING!	
	<p>Danger by inappropriate start-up and operation! Inappropriate start-up and operation can cause severe or lethal injuries.</p> <p>Therefore:</p> <ul style="list-style-type: none"> – Commissioning and operation must be performed by specialists or electricians. – Always observe the radius of action of the barrier boom. – Prior to start of works ensure that all housing covers are correctly mounted.

Wind forces over 10 Beaufort

⚠ WARNING!	
	<p>Risk of injury from breaking off barrier booms in case of high wind speeds! In case of wind speeds exceeding 10 Beaufort, the barrier boom may break off from the wind load and cause severe injuries.</p> <p>Therefore observe in case of storm warnings above 10 Beaufort:</p> <ul style="list-style-type: none"> – Disassemble barrier boom or secure it with suitable measures. – Stop operating the barrier system.

Personal protective equipment

The following must be worn during start-up:

- Work clothes
- Protective gloves
- Safety shoes
- Protective helmet.

Start-up and operation

11.2 Commissioning

Check before to initial start-up

The following inspections must be performed prior to initial start-up:

- Check electrical connections.
- Check barrier boom position.
- Check balancing springs in the lever system and adjust if required.

Inspection during the first start-up

The following inspections must be performed prior to first start-up:

- Check programme mode. → See page 106, chapter 10.7.
- Check parameterisation in connection with wiring.
- Testing and setting the operating frequency of the induction loops. → See page 138, chapter 10.15.1.
- Check the function of the barrier, induction loops, and the signalling devices.

11.3 Switching on and off the barrier

NOTICE!



A too early mains voltage power up after a shut down can result in damage of the equipment!

Therefore:

- Wait for at least 10 seconds after shutting off the mains voltage before you switch the mains voltage on again.

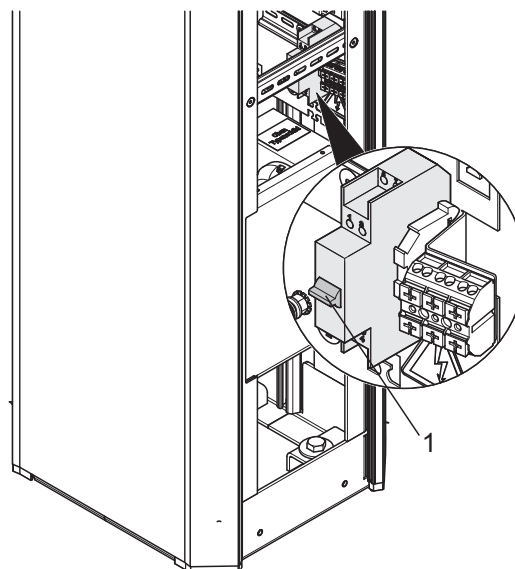

Mag00376

Fig. 54: Switching on and off barrier

1 2-pole mains switch

Switching on

1. Remove the barrier housing hood.
2. Remove the barrier housing door.
3. Switch on the barrier via the 2-pole mains switch.
4. Depending on the settings in the "Start-up behaviour" menu, the barrier boom slowly moves into the top end position (homing run) or stops.
5. Mount the door.
6. Attach and lock the hood.

Switching off

1. Remove the barrier housing hood.
2. Remove the barrier housing door.
3. Switch off the barrier via the 2-pole mains switch.
4. Depending on the settings of the lever system's balancing spring and the settings in the menu "power outage behaviour", the barrier boom opens or closes. → See page 72, chapter 8.13 and page 125, chapter 10.10.8.
5. Mount the door.
6. Attach and lock the hood.

11.4 Putting the barrier temporarily out of operation

High wind speeds

⚠ WARNING!	
	<p>Risk of injury from barrier boom in case of high wind speeds!</p> <p>The barrier boom is no longer securely locked with the mains voltage off. At high wind speeds, the barrier boom can be pressed from its end position. The moving barrier boom can severely injure a person.</p> <p>Therefore:</p> <ul style="list-style-type: none"> – Keep supplying the barrier with mains voltage. – Remove the barrier boom if necessary.

NOTICE!	
	<p>Possible damage to the equipment by condensed water when mains voltage is switched off!</p> <p>Therefore:</p> <ul style="list-style-type: none"> – Keep supplying the barrier with mains voltage.

Start-up and operation

If the barrier is put out of operation for a longer period, proceed as follows:



1. Switch off barrier. → See page 146, chapter 11.3.
2. Remove the barrier boom if necessary. → See page 164, chapter 14.3.
3. Protect the barrier from corrosion and contamination.
4. Switch on barrier. → See page 146, chapter 11.3.

12 Maintenance

12.1 Safety

→ See also safety notes on page 17, chapter 2.6 "Occupational safety and special dangers".

General

 WARNING!	
	<p>Danger by inappropriate maintenance! Inappropriate maintenance can cause severe or lethal injuries.</p> <p>Therefore:</p> <ul style="list-style-type: none">– All maintenance work must be performed by specialists or electricians.– Prior to work, ensure that there is sufficient assembly space.– Pay attention to tidiness and cleanness at the assembly site! Loosely stacked or lying around components and tools are accident sources.– After completion of maintenance work, ensure that all covers are correctly mounted.– Wear protective helmet.

Personal protective equipment

The following must be worn during maintenance work:

- Work clothes
- Protective gloves
- Safety shoes
- Protective helmet.

Maintenance book

We recommend keeping a test book, to properly document all maintenance work.

Maintenance

12.2 Cleaning

Aggressive cleaning aids and substances

The cleaning interval essentially depends on the environmental conditions and the climate.

NOTICE!	
	<p>Unit damage possible!</p> <p>Aggressive detergents and consumables may damage or destroy components, electric cables, or the coating of the barrier.</p> <p>Therefore:</p> <ul style="list-style-type: none"> – Do not use cleaning agents with aggressive ingredients.

Carrying out cleaning work:

1. Switch off power supply and secure against restarting.



DANGER!

Mortal danger by electric voltage!

- Keep moisture and dust away from live parts. Moisture or dust may cause a short circuit.
 - Never clean the barrier housing and barrier boom with vapour or pressure-jet cleaners.
2. Remove contamination from the outside of the barrier housing properly using water with washing-up liquid and a square of cloth. Do not bring control units and electrical components in contact with moisture.
 3. Remove dust inside the housing with a vacuum cleaner.
 4. After cleaning work, check that all previously opened covers are closed again and that all safety equipment functions correctly.

12.3 Maintenance schedule

The following describes the maintenance work that is necessary for optimal, trouble-free operation. Maintenance intervals must be observed.

If increased wear of individual components or functional groups is revealed during regular inspections, the operator must reduce the required maintenance intervals on the basis of the actual signs of wear.

In case of questions on maintenance work and intervals, contact your dealer. Procure spare parts from your dealer or directly from the manufacturer. For the address, see invoice, delivery note or the reverse of these instructions.

Interval	Maintenance work	To be carried out by
Monthly	Visual inspection of the housing, inside and out, for damage and corrosion. Clean the housing and repair paint damage as necessary. Remove corrosion damage.	Specialist
	Visual inspection of foundation anchors, U-profiles and mounting material for corrosion. Remove corrosion damage.	Specialist
	Visual inspection of the barrier boom for damage and corrosion. Clean the barrier boom and repair paint damage as necessary. Remove corrosion damage.	Specialist
	Visual inspection of additional parts, nesting posts and the pendulum support for damage and corrosion. If necessary, clean additional parts, nesting posts and pendulum support and repair paint damage. Remove corrosion damage.	Specialist
	Where they exist, inspect lenses and mirrors of the light barriers.	Specialist
Every 6 months	Check function of the residual current operated device	Electricians
	Check the barrier casing fastening screws for tight fit. If required, tighten the screws.	Specialist
	Check the screws of the additional parts, pendulum support and nesting post for tight fit. If required, tighten the screws.	Specialist
	Check the barrier boom and flange fastening screws for tight fit. If required, tighten the screws.	Specialist

Maintenance

Interval	Maintenance work	To be carried out by
Every 12 months	Check the barrier's mechanics.	MHTM MicroDrive service specialist
	Check the spring setting of the lever system.	
	Check barrier boom position.	
	Visual inspection of the induction loops and the carriageway for damage.	
	Check the induction loops' function. → See page 138.	
	Check the induction loops. Measure the contact resistance, insulation resistance, and inductance of the induction loops. → See page 54.	
	Where they exist, check the function of additional safety equipment, such as light barriers.	
	Check the barrier's function.	
	Check the parameter settings. → See page 99 et seq.	
	Check the barrier's locking in the position "Closed".	
	Check the advanced warning on barriers with the active function "Traffic lights lead".	
	Check electric cables for damages.	
	Check if all electrical connections are firm.	
	Check signs and labels for legibility.	
Check foundation fastening.		
The cleaning interval depends on the environmental conditions and the climate.	Cleaning barrier boom.	Specialist
	Clean barrier housing from the inside.	Specialist

Table 49: Maintenance schedule

13 Malfuncions



This chapter describes possible causes of malfunctions and trouble shooting tasks.

Contact your dealer in case of malfunctions that cannot be repaired by means of the following information. Procure spare parts from your dealer or directly from the manufacturer. For the address, see invoice, delivery note or the reverse of these instructions.

13.1 Safety



→ See also safety notes on page 17, chapter 2.6 "Occupational safety and special dangers".

General

 WARNING!	
	<p>Danger of injury from inappropriate troubleshooting!</p> <p>Inappropriate troubleshooting can cause severe or lethal injuries.</p> <p>Therefore:</p> <ul style="list-style-type: none"> – All troubleshooting work must be performed by specialists or electricians. – Observe possible movements of the barrier boom. Defective control may lead to inadvertent movement of the barrier boom. – Prior to work, ensure that there is sufficient assembly space. – Pay attention to tidiness and cleanness at the assembly site! Loosely stacked or lying around components and tools are accident sources. – Deactivate the barrier if any components are damaged, e.g. the barrier boom. – After completion of troubleshooting, ensure that all covers are correctly mounted.

Malfuncions

Danger of injury after lightning strike

 WARNING!	
	<p>Danger of injury from total outage or barrier malfunction after lightning has hit the barrier!</p> <p>If the barrier is struck by lightning, this may lead to total outage or malfunction of the barrier. The malfunction may cause unexpected barrier behaviour and thus lead to serious injury!</p> <p>Therefore:</p> <ul style="list-style-type: none"> – If the barrier is struck by lightning, have an electrician check the barrier for damage and proper function. Repair barrier if required. – Observe possible movements of the barrier boom. Defective control may lead to inadvertent movement of the barrier boom.

13.2 Malfunction table – barrier malfunctions

→ For requirements to the MHTM MicroDrive service specialist, see page 16, chapter 2.4.1.

Malfunction	Possible cause	Corrective action	To be carried out by
Barrier out of operation. The message "Safety device missing" appears on the display.	No safety loop is connected to the plug-in module "Detector" and no safety light barrier to the clamps X11 and X20.	Connect either the safety loop or safety light barrier. → See page 168, chapter 17.1.	Electrical specialist
	The safety device is defective.	Replace safety device.	
Barrier does not open.	Power supply is not connected	<ul style="list-style-type: none"> ■ Switch on power supply. ■ Check power supply. 	Electrical specialist
	Error present. The corresponding error message is displayed.	Depending on error message, check components, wiring, etc.	MHTM MicroDrive service specialist
	Power supply is present. Control unit display does not light up.	Control unit defective. Replace the control unit. Contact service.	MHTM MicroDrive service specialist
	Loop interference due to external loop detectors or other barriers in the proximity.	Check the operating frequency of the loops and adjust if necessary	MHTM MicroDrive service specialist
	Closing signal is active.	Remove closing signal	Electrical specialist
Barrier does not open completely.	Spring tension in the balancing springs of the lever system set too weakly for the barrier boom weight.	Adjust balancing springs. → See page 72, chapter 8.13.	MHTM MicroDrive service specialist

Malfunctions

Malfunction	Possible cause	Corrective action	To be carried out by
Barrier does not close immediately after through traffic, but only after the hold-open time.	Opening signal is active for too long.	Shorten opening signal to max. 1 second.	Electricians
	Safety loop does not respond.	Check the response sensitivity of the safety loop. Adjust setting if necessary.	MHTM MicroDrive service specialist
Barrier does not close.	Opening command is active.	Cancel the opening command.	Electricians
	Induction loop reports engaged, although no vehicles are present.	<ul style="list-style-type: none"> ■ Check and if necessary adjust loop frequencies. ■ Measure loops. Insulation resistance: > 1 Mohm contact resistance: 0.8 to 2.5 ohm Replace loop if the measured values differ from the specified values.	MHTM MicroDrive service specialist
	Wire bridge between terminals X11 IN and OUT missing.	If no safety light barrier is connected, a wire bridge must be installed between the clamps X11 OUT and IN. → See page 168, chapter 17.1.	MHTM MicroDrive service specialist
Barrier does not close. The message "Waiting for release" appears on the display.	The message appears after the voltage supply is switched on, after voltage returns and after reset.	The release signal can be given by an external closing signal or by pushing the left operating button at the control unit. → See page 125, chapter 10.10.8.	Operator
Barrier does not close. The message "Waiting for authorization" appears on the display.	The message appears after the voltage supply is switched on, after voltage returns and after reset.	<ul style="list-style-type: none"> ■ The barrier closes once a vehicle passes. → See page 125, chapter 10.10.8. ■ Confirm message via the left button at the control device. 	Operator
Barrier does not close completely.	Spring tension in the balancing springs of the lever system set too strongly for the barrier arm weight.	Adjust balancing springs. → See page 72, chapter 8.13.	MHTM MicroDrive service specialist
	Impact was recognized.	Wait several seconds, barrier closes if no obstacle is below the barrier arm anymore.	

Malfuncions

Malfuncion	Possible cause	Corrective action	To be carried out by
Barrier does not close. The display shows: 	Loop not connected.	Connect loop	MHTM MicroDrive service specialist
	Detector mode incorrectly parameterised.	Check the parameters of the detector module and correct it if necessary. → See page 137, chapter 10.15.	
	Loop defective.	Replace loop.	
	Transfer resistance at the terminals	Cut connecting leads, strip and connect them again without end sleeves.	
Barrier closes, although a vehicle is standing on the safety loop.	"Safety loop" not selected for "Mode A" or "Mode B" in the menu "Detector 1 (A-B)".	Select option "Safety loop".	MHTM MicroDrive service specialist
	Cut off angle incorrectly parameterised.	Check and adjust the cut off angle.	
	Too low trigger sensitivity set for the loop.	Check the response sensitivity of the loop and adjust if necessary.	
	Inappropriate loop geometry is installed.	Install an appropriate loop geometry.	
	Loop interference due to external loop detectors or other barriers in the proximity.	Check the operating frequency of the loops and adjust if necessary	
	Safety light barrier connected incorrectly or defective.	Check safety light barrier function.	
	User misbehaviour e.g. driving into closing barrier, or following behind another vehicle.	<ul style="list-style-type: none"> ■ Retrofit signal light, such as red/green signal light and parameterise lead time. ■ Upgrade signs. 	Operator

Table 50: Malfunction table – Barrier

13.3 Warning and interference messages on the display

The control unit display indicates the corresponding warning or error message in case of an error.

Warning messages

Warning messages serve as notice. The barrier continues to operate normally.

Error messages

In case of error messages, the barrier is shut down. For the barrier to be started up again, the error must be removed by an MHTM MicroDrive service specialist and a reset performed pursuant to chapter 13.4.

→ For requirements to the MHTM MicroDrive service specialist, see page 16, chapter 2.4.1.

13.3.1 Warning and interference messages – Logic control (control unit)

Number	Designation	Possible cause	Corrective action
FF01 WARNING	Barrier mechanical fault	The first closing motion could not be performed completely.	<ul style="list-style-type: none"> ■ If required, remove obstacle below the barrier boom. ■ Check barrier mechanics. ■ Check the spring setting of the balancing springs.
FF02 WARNING	Detector safety signal	Communication between logic control and detector module impaired.	<ul style="list-style-type: none"> ■ Perform reset. → See page 161, chapter 13.4. ■ Check plug contacts. ■ Clean plug contacts with spirit. Observe ESD provisions. ■ Replace the control unit.
FF03 ERROR	Safety device missing	No monitoring loop is connected to the detector module and no safety light barrier to the clamps X11 and X20.	Connect either the safety loop or safety light barrier. → See page 168, chapter 17.1.
		Safety device defective	Replace safety device.
		Sensitivity settings in the "Detector" menu too low. Not all vehicles are recognised.	Change sensitivity. → See page 137, chapter 10.15.
FF04 ERROR	Barrier too fast	Spring tension in the balancing springs of the lever system set too weakly for the barrier boom weight.	<ul style="list-style-type: none"> ■ Adjust balancing springs. → See page 72, chapter 8.13. ■ Contact service if required.
FF05 WARNING	Boom contact / Swing-sway active	At the "Boom contact" input, boom ejection was detected.	<ul style="list-style-type: none"> ■ Replace the barrier boom ■ If required, choose the option "Off" in the "Boom contact settings" menu. ■ Verify cables.

Malfuncions

Number	Designation	Possible cause	Corrective action
FF06 WARNING	Vandalism	The barrier boom was either lifted from the lower end position or stopped when closing.	In the closed position, check that the lever system latches.
FF30 WARNING	Impact detection	Impact was recognised by the input "external impact contact".	<ul style="list-style-type: none"> ■ Wait for a few seconds. The barrier closes if no obstacle is below the barrier boom anymore. ■ When no obstacle is present below the barrier boom, check input, e.g. contact strip.
3120 ERROR	Mains power failure	Short-term mains outage was recognised	<ul style="list-style-type: none"> ■ Check supply voltage/mains quality
5530 ERROR	EEPROM checksum	Check sum of the parameter incorrect	<ul style="list-style-type: none"> ■ Re-set parameters to factory defaults. → See page 144, chapter 10.18. ■ Contact service if required.
6000 ERROR	Module update error	A firmware update was not performed correctly.	<ul style="list-style-type: none"> ■ Restart the control unit ■ If the error continues to be present, perform the update again via the service module.
6102 ERROR	Software error system bus	Within the control, an error is pending in communication.	<ul style="list-style-type: none"> ■ Check FW versions of all plug-in modules. If required, perform update via service module. ■ If all FW versions are up to date, contact service.
6105 ERROR	Error on homing	The barrier could not perform any reference run.	<ul style="list-style-type: none"> ■ Check motor communication. ■ Check mechanics. ■ Perform reset. → See page 161, chapter 13.4.
8130 WARNING	Heartbeat error	Communication with a plug module was interrupted.	<ul style="list-style-type: none"> ■ Check if all plugged modules are listed in the main menu. ■ Perform reset. → See page 161, chapter 13.4. ■ Contact service if required.

Table 51: Warning and interference messages – logic control (control unit)

13.3.2 Warning and interference messages – Motor GW

Number	Designation	Possible cause	Corrective action
2220 WARNING	Over current	Overcurrent was recognised	<ul style="list-style-type: none"> ■ Warning may appear in connection with impact. ■ If no impact took place, check the cables. ■ Contact service if required.
3211 WARNING	Over voltage	Overvoltage was recognised	<ul style="list-style-type: none"> ■ Warning may appear in connection with impact. ■ If no impact took place, check the cables. ■ Contact service if required.
3221 WARNING	Under voltage	Undervoltage was recognised	<ul style="list-style-type: none"> ■ Warning may appear in connection with impact. ■ If no impact took place, check the cables. ■ Contact service if required.
4210 WARNING	Over temperature	A high temperature was recognised.	<ul style="list-style-type: none"> ■ Check motor temperature via display. The temperature must be below 100 °C. → See page 136, chapter 10.14. ■ Contact service if required.
4220 WARNING	Derating error	Motor power intake is reduced to avoid further temperature increase.	<ul style="list-style-type: none"> ■ Remove impermissible attachments ■ Check the spring setting of the balancing springs. ■ Reduce speed of the barrier boom. ■ Contact service if required.
FF30 WARNING	Impact detection	Impact was recognised.	<ul style="list-style-type: none"> ■ Check safety devices. ■ Adjust menu "Cut off angle". → See page 120, chapter 10.10.3. ■ If there was no impact on an obstacle/vehicle, check the spring settings of the balancing springs and mechanics.
7510 ERROR	Motor communications error	Communication between motor and control impaired or interrupted	<ul style="list-style-type: none"> ■ Verify cables ■ Contact service if required.
FF32 ERROR	HW-Enable-Test failed	–	Contact service.
FF33 ERROR	Safety device test failed (LS-Test failed)	Safety light barrier test failed	Check light barrier and light barrier connection.

Malfuncions

Number	Designation	Possible cause	Corrective action
FF37 ERROR	Motor update failed	An error occurred when updating the software	<ul style="list-style-type: none"> ■ Perform reset. → See page 161, chapter 13.4. ■ Contact service if required.
FF3A WARNING	Motor update performed	Message serves information purposes	–

Table 52: Warning and interference messages – Motor GW

13.3.3 Warning and interference messages – detector

Number	Designation	Possible cause	Corrective action
FF4A ERROR	Hardware error	Internal HW function test failed	<ul style="list-style-type: none"> ■ Perform reset. → See page 161, chapter 13.4. ■ Contact service if required.
FF4B WARNING	Loop error A or C	Short circuit or idle loop A or C	<ul style="list-style-type: none"> ■ Remove loop error and perform adjustment. ■ If no loop is connected, select the option "Inactive" in the menu "Detector".
FF4C WARNING	Loop error B or D	Short circuit or idle loop B or D	<ul style="list-style-type: none"> ■ Remove loop error and perform adjustment. ■ If no loop is connected, select the option "Inactive" in the menu "Detector".

Table 53: Warning and Interference Messages - Detector

13.3.4 Warning and interference messages – All modules

Number	Designation	Possible cause	Corrective action
6010 WARNING	Watchdog reset	SW error	Contact service if required.
8110 WARNING	Bus fault	Warning	Contact service if required.
8120 WARNING	Bus HW fault	Warning	<ul style="list-style-type: none"> ■ Check DIP switch next to service interface (position ON) ■ Remove devices at service interface if required.

Table 54: Warning and interference messages – All modules

13.4 Reset the barrier

Control unit reset is performed as follows:

- Switch of power supply and switch it on again after 10 seconds.
- or
- Press the two middle control buttons on the display for 5 seconds. → See page 100, Fig. 45.

NOTICE!



Damage to the unit by too-short switching intervals of the mains voltage!



Therefore:

- To avoid damage to the equipment the power must remain shut off for at least 10 seconds.

Malfuncions

13.5 Closing or opening the barrier boom in case of power failure

Danger of crushing, lever system

 WARNING!	
	<p>Danger of crushing at opened barrier housing at the lever system!</p> <p>The lever system in the barrier housing can cause serious crushing injuries!</p> <p>Therefore:</p> <ul style="list-style-type: none"> – Only specialists must manually close or open the barrier boom at voltage failure. – Wear protective gloves if necessary.

In case of power failure, the barrier boom may be in the lower or upper dead point. I.e. the barrier boom can no longer be easily moved manually. In this case, proceed as follows:

1. Remove the barrier housing hood.
2. Remove the barrier housing door.
3. Push the coupling rod from the dead point manually. See the following figure.
4. Mount the door if applicable.
5. Attach and lock the hood if applicable.

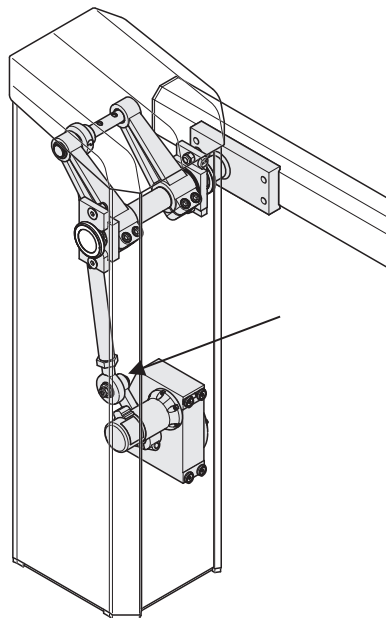

Mag00413



Fig. 55: Closing and opening barrier boom manually

14 Repair

14.1 Safety

→ See also safety notes on page 17, chapter 2.6 "Occupational safety and special dangers".

General

 WARNING!	
	<p>Danger by inappropriate repair!</p> <p>Inappropriate repair can cause severe or lethal injuries.</p> <p>Therefore:</p> <ul style="list-style-type: none"> – All repair work must only be performed by authorised MHTM service specialists. – Prior to work, ensure that there is sufficient assembly space. – Pay attention to tidiness and cleanness at the assembly site! Loosely stacked or lying around components and tools are accident sources. – Only use original spare parts or spare parts approved of by MAGNETIC. Procure spare parts from your dealer or directly from the manufacturer. For the address, see invoice, delivery note or the reverse of these instructions. – After completion of repair work, ensure that all covers are correctly mounted.



Personal protective equipment

The following must be worn during all repair work:

- Work clothes
- Protective gloves
- Safety shoes
- Protective helmet.

Repair

14.2 Spare parts



 WARNING!	
	<p>Risk of injury by incorrect spare parts!</p> <p>Incorrect or defective spare parts can result in damage, malfunctions or total failure and also impair safety.</p> <p>Therefore:</p> <ul style="list-style-type: none"> – Use only the manufacturer's original spare parts.

Procure spare parts from your dealer or directly from the manufacturer. For the address, see invoice, delivery note or the reverse of these instructions.

Spare part lists can be obtained on request.

14.3 Replacing the barrier boom

Danger of injury

 CAUTION!	
	<p>Danger of injury!</p> <p>There is a danger of injury when mounting the barrier boom.</p> <p>Therefore:</p> <ul style="list-style-type: none"> – Barrier booms must be mounted by two persons.

1. Secure barrier danger area e.g. with barrier tape.
2. Remove the barrier housing hood.
3. Remove the barrier housing door.



WARNING!

Danger of crushing between barrier boom and barrier housing!

4. Switch off power supply. Ensure that the system is powered down. Secure against reactivation. The balancing springs in the lever system are relaxed. The barrier boom is vertical.
5. Disassemble barrier boom.
6. Assemble new barrier boom. For barrier booms up to 6 metres see page 62, chapter 8.9. For barrier booms as of 6 metres see page 63, chapter 8.10.

15 Decommissioning, disassembly and disposal

A barrier that is no longer usable should not be recycled as a complete unit, but disassembled into individual components and recycled according to material types. Non-recyclable materials have to be disposed of in an environmental-friendly manner.

- Decommissioning, disassembly and disposal of the barrier may only be carried out by specialised staff.
- Disassemble the barrier in reverse order from assembly.
- The barrier has to be disposed of in accordance with the respective country-specific regulations.



NOTE!

For expert information regarding disposal of electric equipment contact MAGNETIC or competent electricians.

16 EC-Declaration of conformity



Der Hersteller/ manufacturer

MAGNETIC Autocontrol GmbH

Grienmatt 20 – 28
D-79650 SchopfheimTelefon +49 (0) 7622 / 695-5
Telefax +49 (0) 7622 / 695-602

Dokumentationsbevollmächtigter/ Documentation Engineer

Herr Stefan Wellinger

Telefon +49 (0) 7622 / 695-719

erklärt hiermit für das von ihm gelieferte Produkt/ *this is to certify that the delivered product*

Bezeichnung / designation	Schranke/ barrier MHTM™ MicroDrive
Typ/ type	ACCESS XL, ACCESS XXL (mit Sicherheitseinrichtungen gemäß Betriebsanleitung / with safety installations accordance with operating instructions)
Ab Serien-Nr./ from serial no.	F05491547

die Konformität nach/ *corresponds to the conformity of***Richtlinie/ directive 2006/42/EG** (Machinenrichtlinie/ *machine directive*)**Richtlinie/ directive 2004/108/EG** (EMV-Richtlinie/ *EMC directive*)Angewandte harmonisierte Normen (oder Teile daraus)/ *Realized harmonized norms (or parts of them):***EN ISO 12100-2 (2004-04)**Sicherheit von Maschinen – Grundbegriffe, allgemeine Gestaltungsleitsätze – Teil 2: Technische Leitsätze/
*Safety of machinery – basic concepts, general principles for design – Part 2: Technical principles***EN 60204-1 (2007-06)**Sicherheit von Maschinen – Elektrische Ausrüstung von Maschinen – Teil 1: Allgemeine Anforderungen/
*Safety of Machinery – Electrical Equipment of Machines – Part 1: Specifications for General Requirements***EN 61000-6-2 (2006-03)**Elektromagnetische Verträglichkeit (EMV) – Teil 6-2: Fachgrundnormen – Störfestigkeit für Industriebereich/
*Electromagnetic compatibility (EMC) – Part 6-2: Generic standards – Immunity for industrial environments***EN 61000-6-3 (2007-09)**Elektromagnetische Verträglichkeit (EMV)- Teil 6-3: Fachgrundnormen – Störaussendung für Wohnbereich,
Geschäfts- und Gewerbebereiche sowie Kleinbetriebe/ *Electromagnetic compatibility (EMC) – Part 6-3: Generic standards –
Emission standard for residential, commercial and light-industrial environments***EN 13849-1 (2008-12)**Sicherheit von Maschinen – Sicherheitsbezogene Teile von Steuerungen – Teil 1: Allgemeine Gestaltungsleitsätze/
Safety of machinery – Safety-related parts of control systems – Part 1: General principles for design

Diese Erklärung ist keine Zusicherung von Eigenschaften im Sinne des Produkthaftungsgesetzes. Die
Sicherheitshinweise der Bedienungsanleitung sind zu beachten./ *This declaration is not a guarantee of characteristics in the
sense of product liability law. The safety regulations of the operating instructions/maintenance instructions have to be observed.*

Schopfheim, den 05.12.2012

Ort und Datum/ *place and date*Unterschrift/ *signature*

Appendix

17 Appendix

17.1 Wiring diagram

Following wiring diagrams apply to standard barriers.
Observe the customer specific wire diagrams for customer specific barriers if applicable.

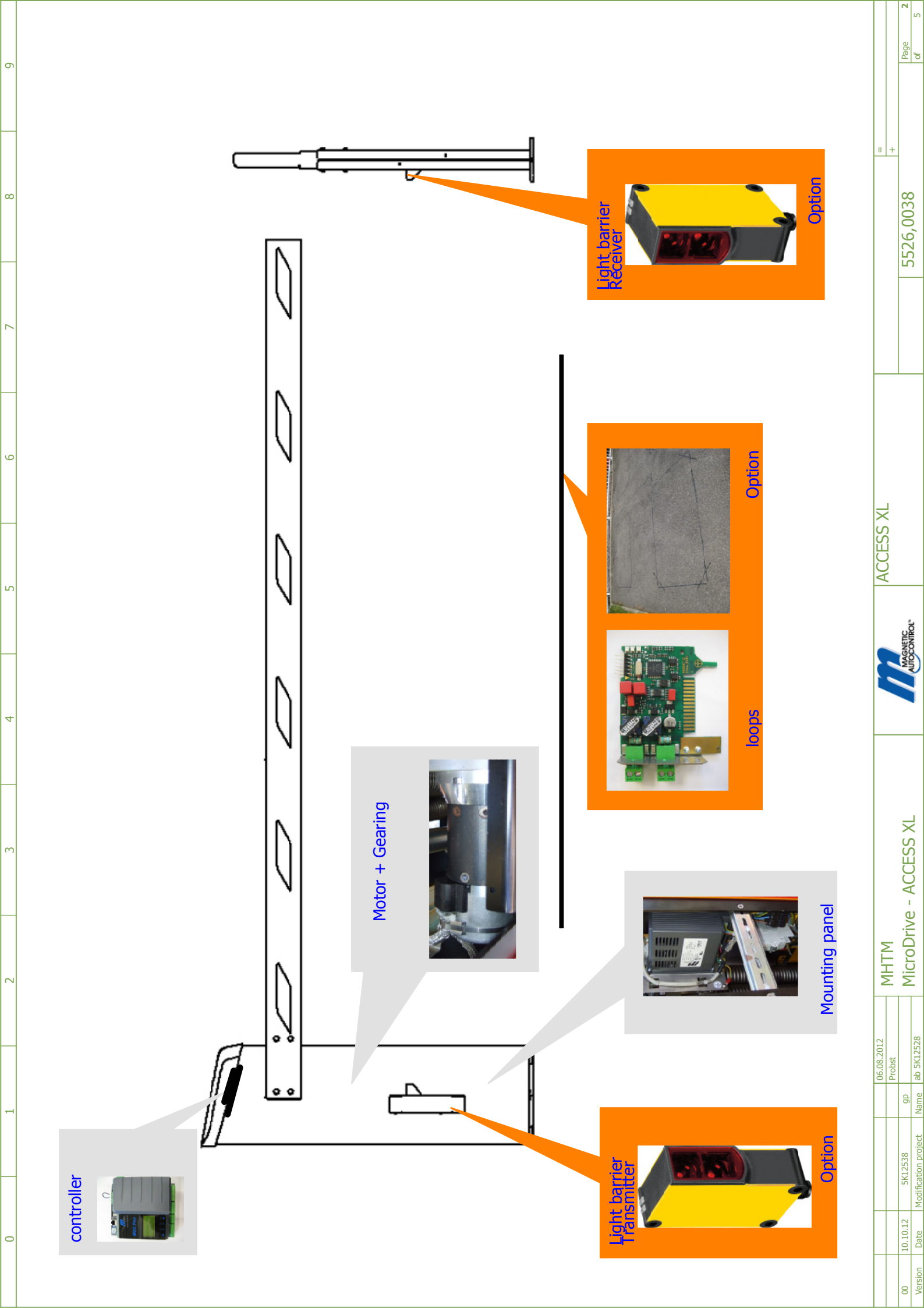

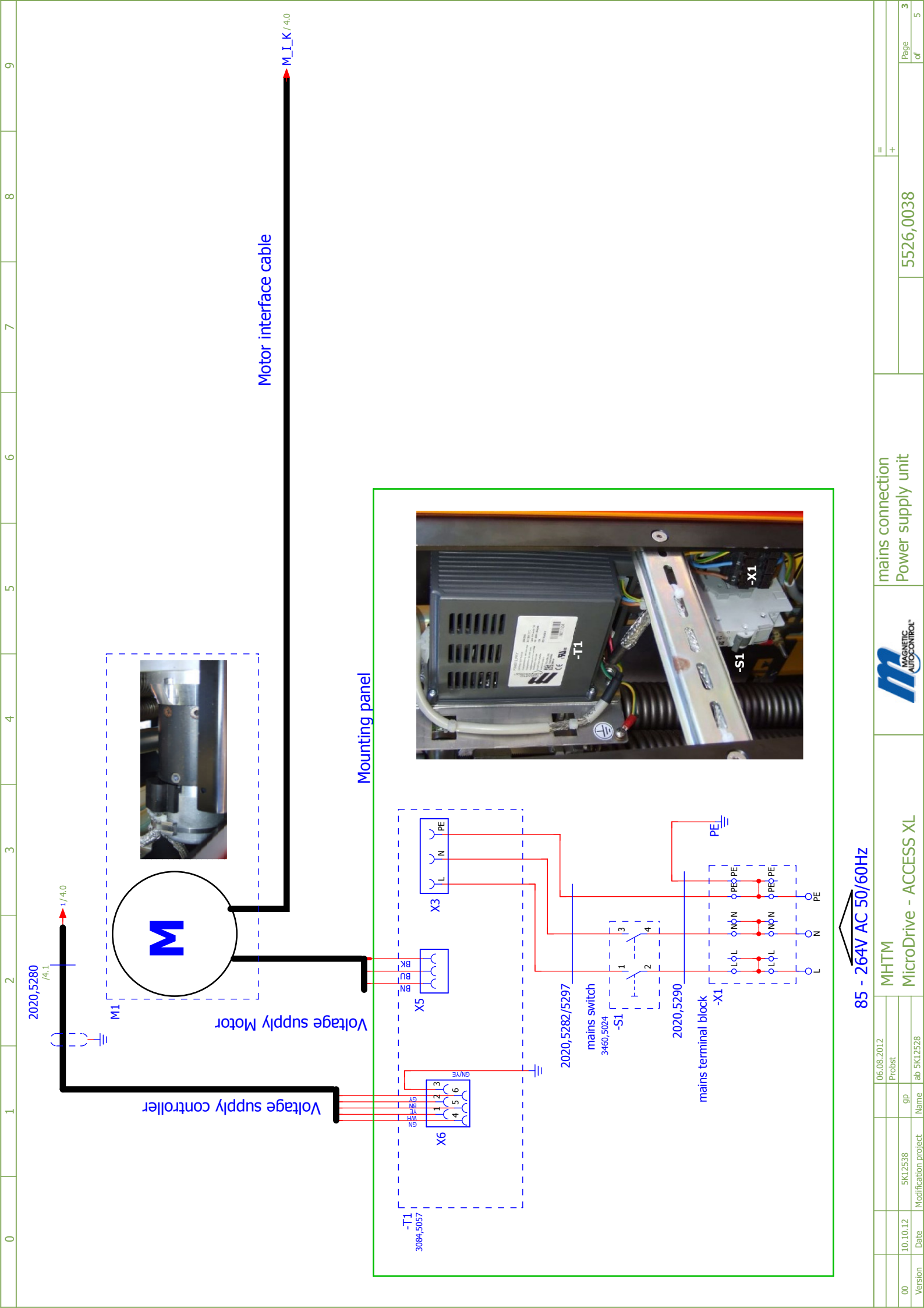

85 - 264V AC 50/60Hz

00	10.10.12	5K12538	9P	Probst	06.08.2012
Version	Date	Modification project	Name	fab 5K12528	

MHTM
MicroDrive - ACCESS XL



mains connection
Power supply unit

5526,0038

=	+	
Page	of	3
		5

Voltage supply cable MGC

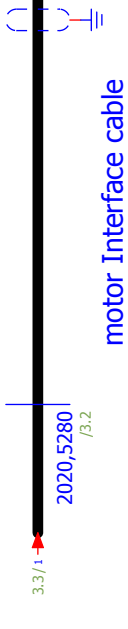

motor Interface cable

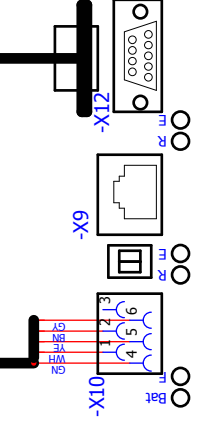

if no safety light barrier is connected, place jumper

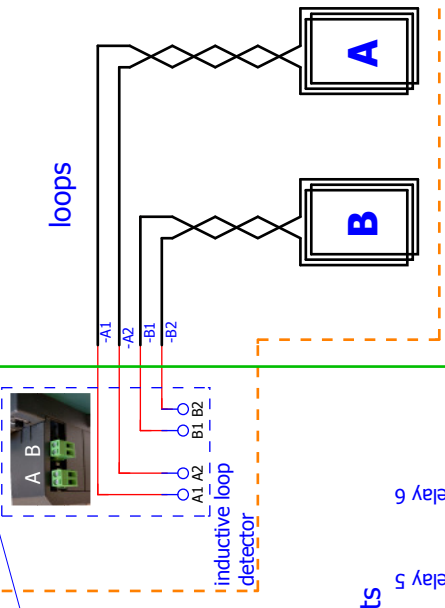

barrier controller MGC-Pro

Transistor Outputs

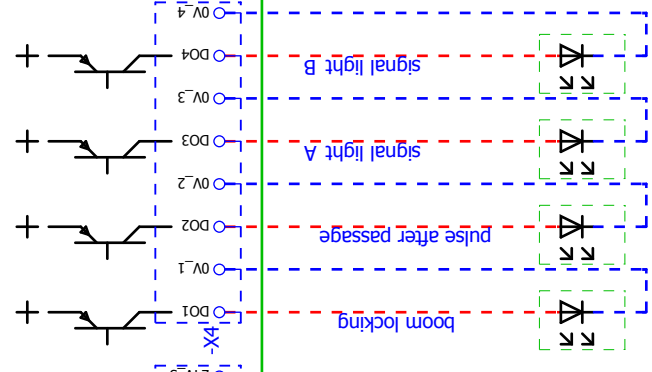

Relay Outputs

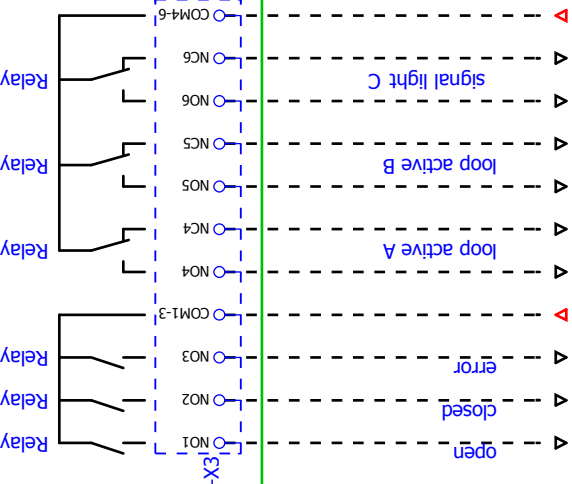

Inputs

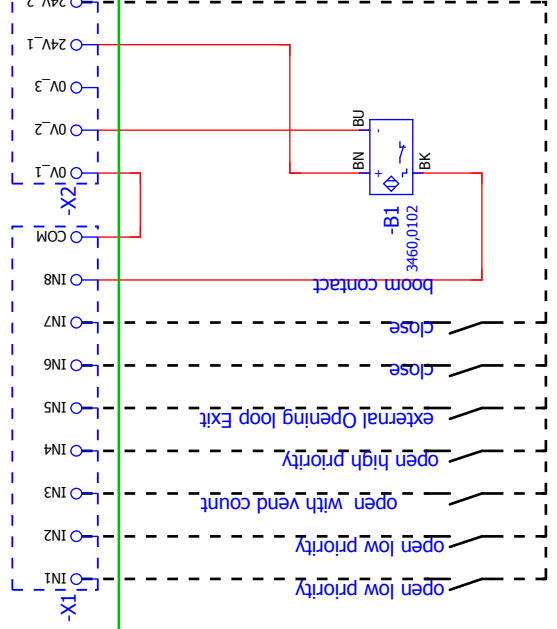

4.9 / P_1
4.9 / OUT
4.9 / OV_1

4.9 / P_2
4.9 / IN
4.9 / OV_2

3279.5028
-A2
BN 24V
WH(n.c.)
BU 0V
BK T

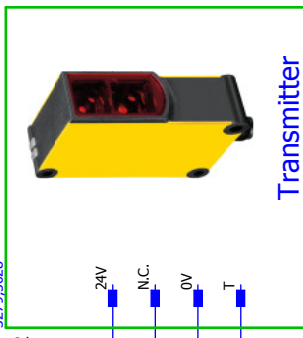

3279.5029
-A3
BN 24V
WH(n.c.)
BU 0V
BK Q

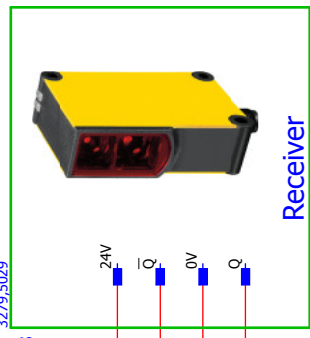

(option)

06.08.2012
Probst

00	10.10.12	5K12538	9P	Name
Version	Date	Modification project	Name	

MHTM
MicroDrive - ACCESS XL



safety-light barriers Option
LS01

5526,0038

=
+

17.2 Menu setup

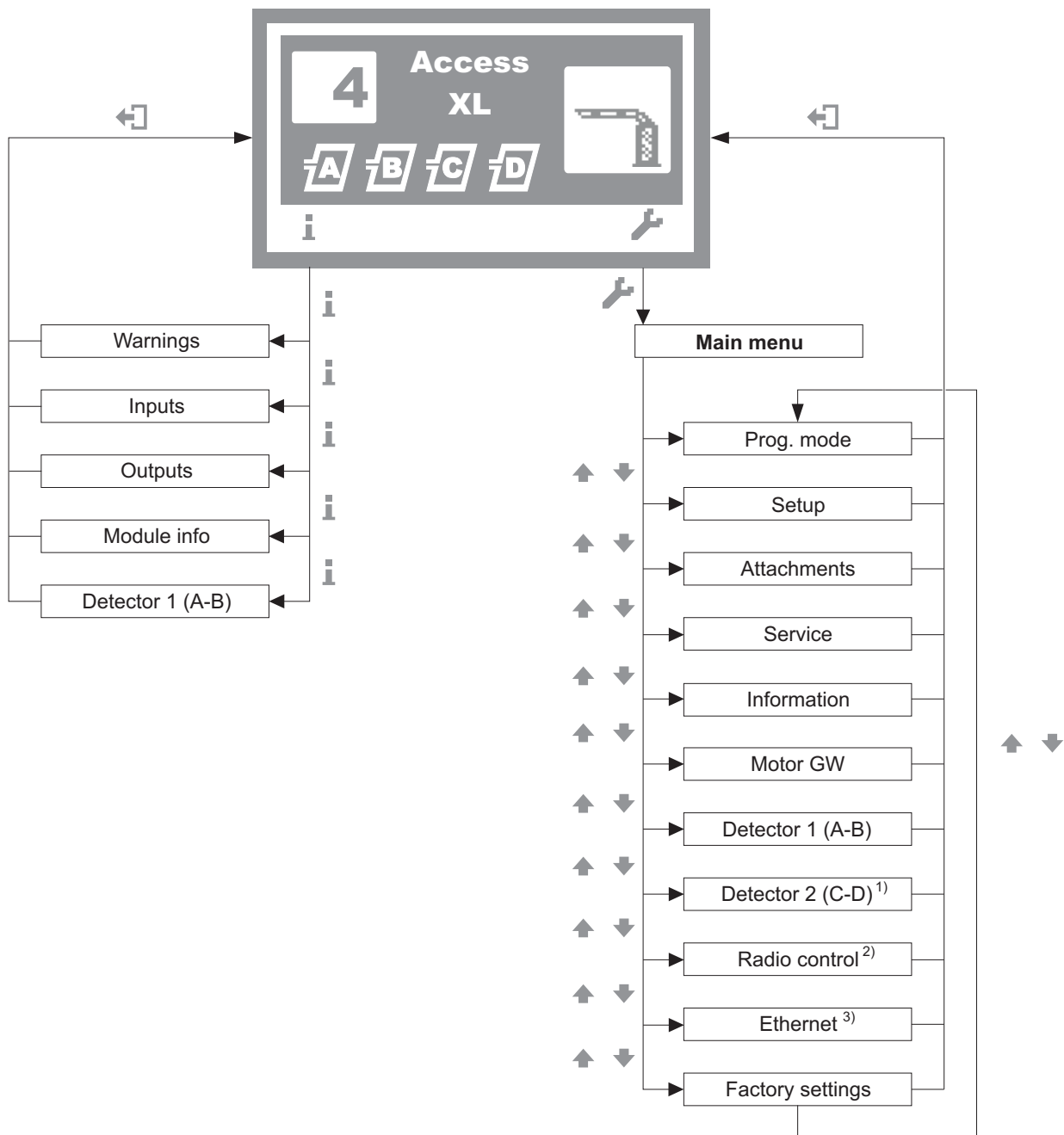
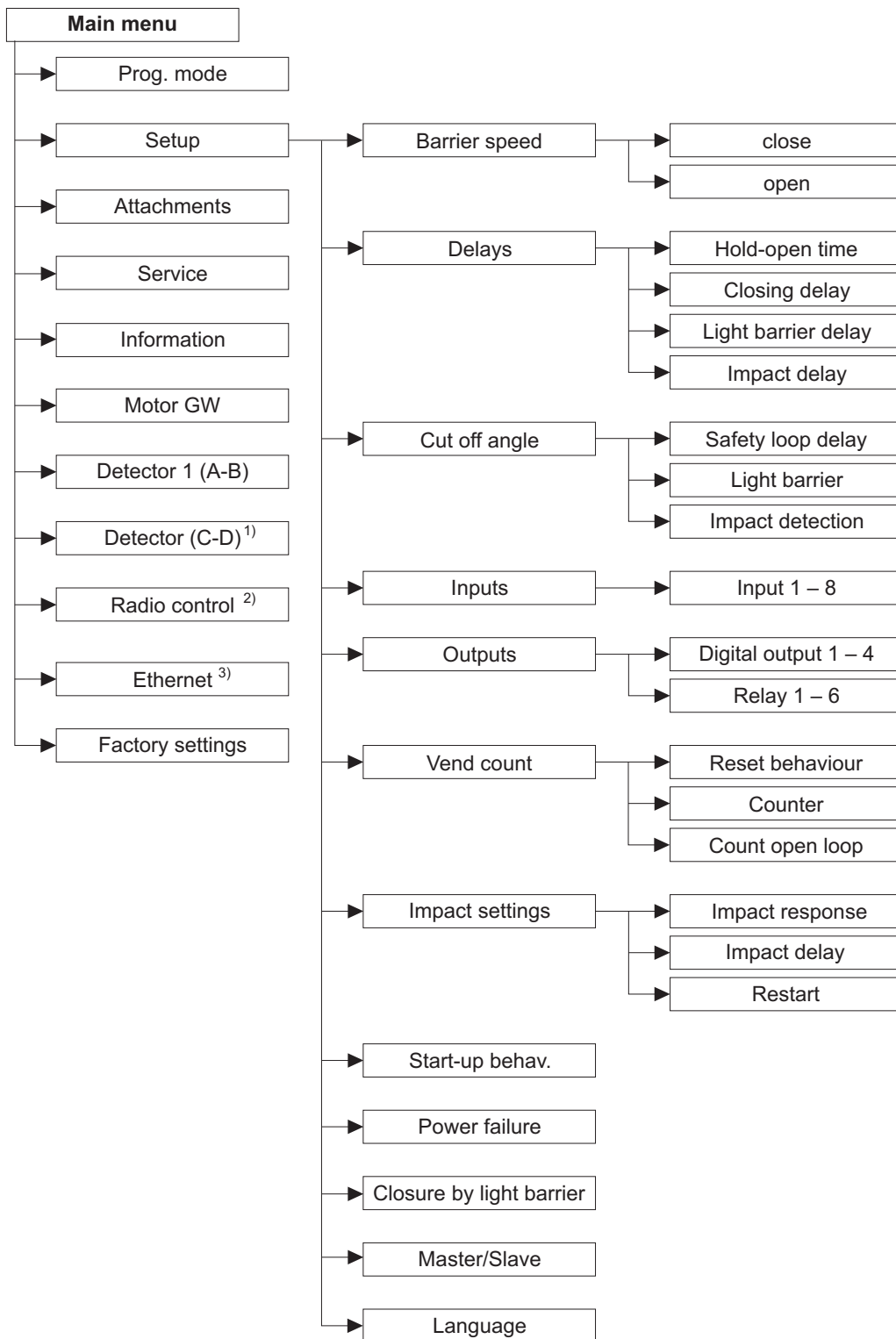

Fig. 56: Menu "Main menu" and "Information"

- 1 Menu "Detector 2 (C-D)" with second "Detector" plug-in module only (optional)
- 2 Menu "Radio control" with optional "Radio" plug-in module only
- 3 Menu "Ethernet" with optional "Ethernet" plug-in module only

Appendix



Mag00411

Fig. 57: Menu "Main menu"

- 1 Menu "Detector 2 (C-D)" with second "Detector" plug-in module only (optional)
- 2 Menu "Radio control" with optional "Radio" plug-in module only
- 3 Menu "Ethernet" with optional "Ethernet" plug-in module only

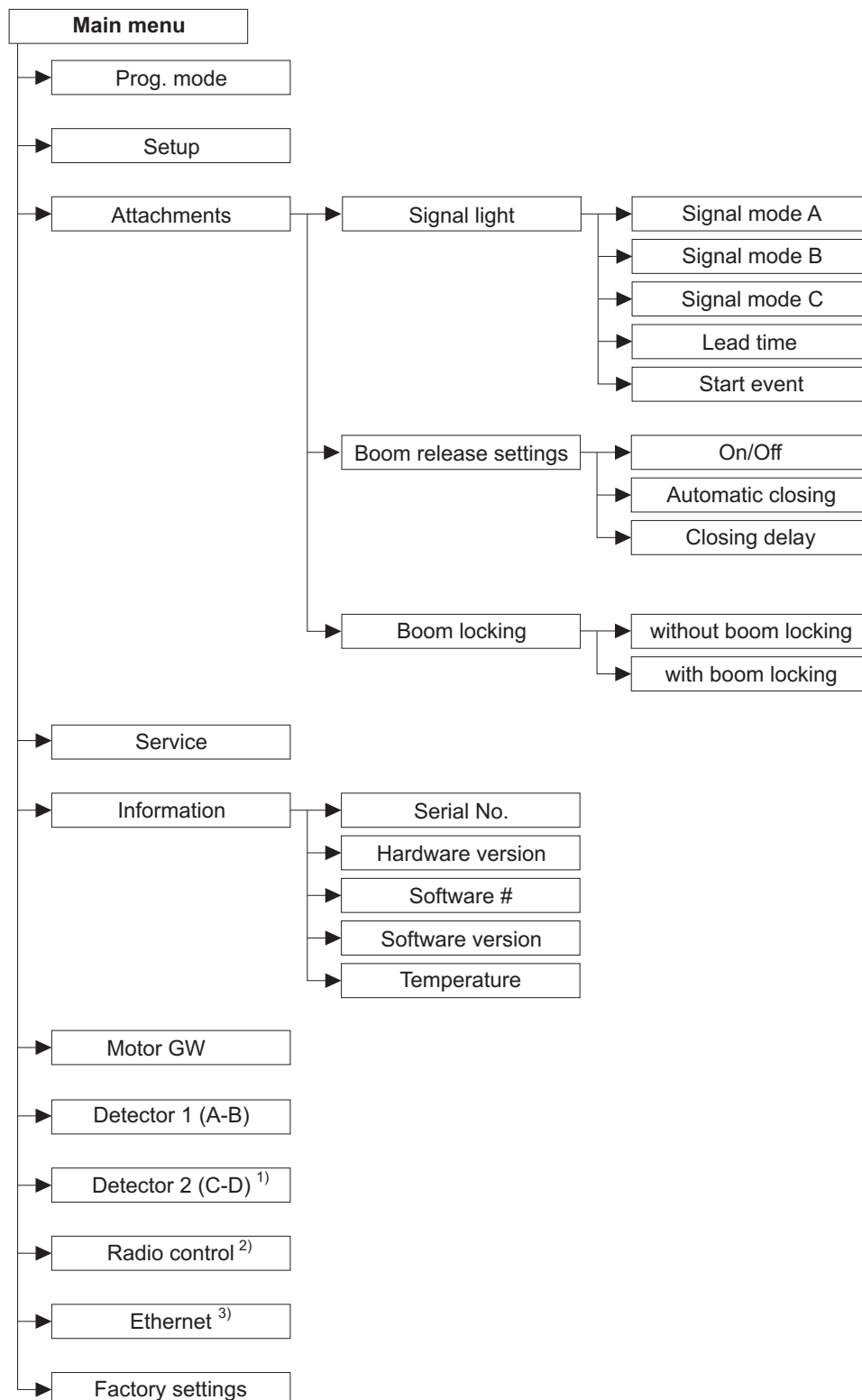

Mag00131d

Fig. 58: Menu "Main menu" – Sub menus "Attachments" and "Information"

1 Menu "Detector 2 (C-D)" with second "Detector" plug-in module only (optional)

2 Menu "Radio control" with optional "Radio" plug-in module only

3 Menu "Ethernet" with optional "Ethernet" plug-in module only

Appendix

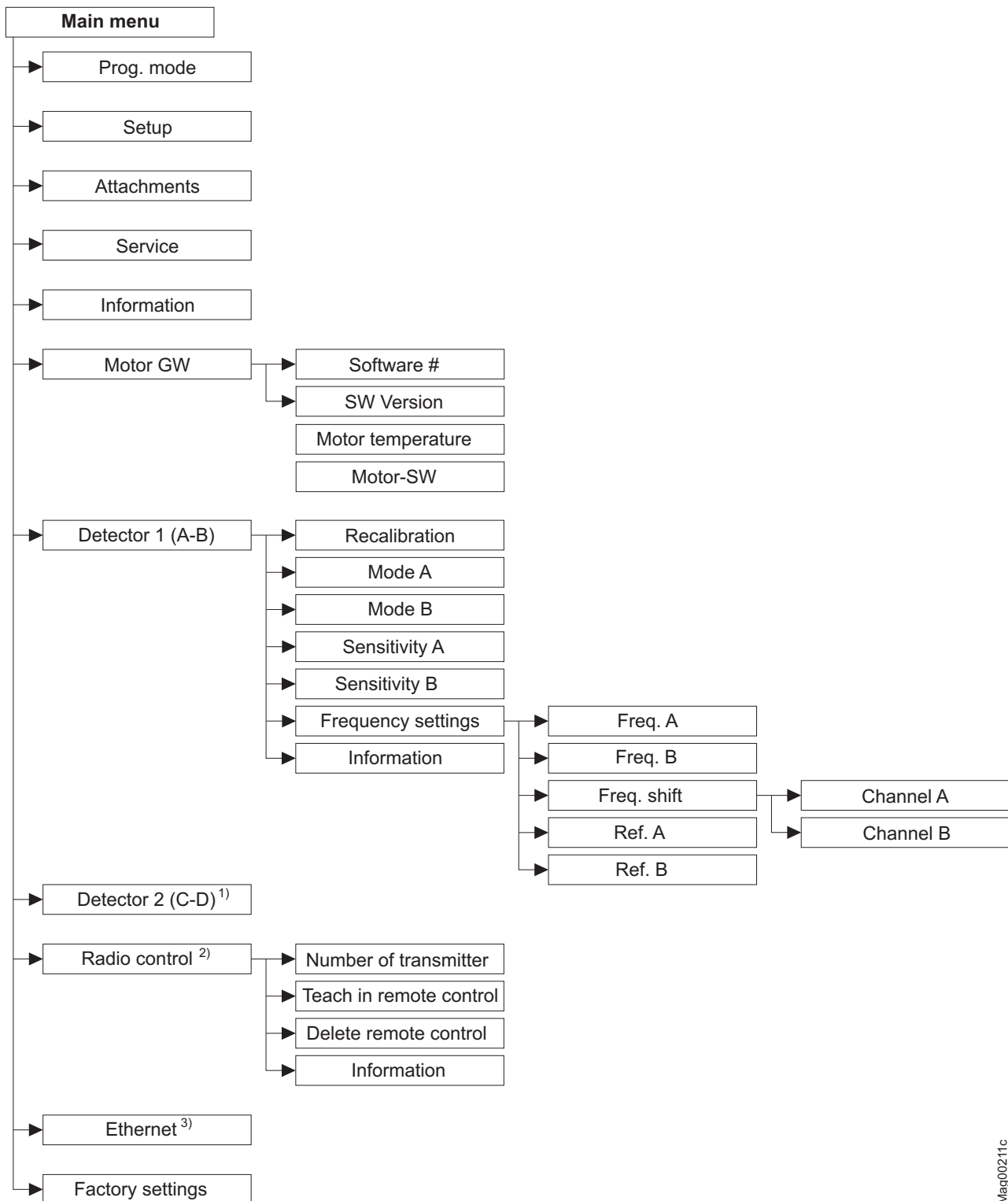

Mag00211c

Fig. 59: Menu "Main menu" – Sub menus "Motor GW", "Detector 1 (A-B)" and "Radio control"

- 1 Menu "Detector 2 (C-D)" with second "Detector" plug-in module only (optional)
- 2 Menu "Radio control" with optional "Radio" plug-in module only
- 3 Menu "Ethernet" with optional "Ethernet" plug-in module only

Index

A	
Assemble housing	57
Assembly	
Housing	57
Safety light barrier	60
Assembly and installation	
Required steps	43
Assembly site	45, 47
Light barrier posts	50
Nesting post	50
B	
Balancing springs	73, 74
Arrangement	78
Check	72
Setting	72
Barrier boom	33
Barrier housing	33
Bistable	109
C	
Change value	100
Changes	15
Check	
Assembly	81
Before to initial start-up	146
Electrical connection	98
Installation	81
Check assembly	81
Check installation	81
Cleaning	150
Commissioning	146
Connecting the power cable	84
Control buttons	
Function	101
Control elements	99
Control unit	
Displays	100
Technical data	31
Control unit control elements	99
Copyright	10
Customer service	11
D	
Danger area	24
Deadman	108
Decommissioning	165
Temporarily	148
Design	33
Digital inputs	91
Digital outputs	94
Dimensions	
Access XL	27
Access XXL	29
Disassembly	165
Disclaimer	11
Display	
Symbols	101
Disposal	165
E	
EC-Declaration of conformity	12
Electrical connection	82
Electricians	16
Empty conduit	
Light barrier	51
Empty conduits	45, 46, 48
Environmental protection	12
F	
Foundation	33, 45, 46, 47, 48
Light barrier post	51
Nesting post	51
Foundation plan	51
Access XL	46
Access XXL	48
Function	34
G	
General	8
H	
Hazard Notes	18
I	
Identification	25
Induction loops	52, 55, 56
Inspection	
During the first start-up	146
Instructed people	16
Intended use	13
L	
Limitation of liability	10
Loop detector plug-in module	
Technical data	32
Lorry loops	39
Lorry/passenger car loops	40
M	
Maintained contact	107
Maintenance	149

Index

Maintenance schedule.....	151	S	
Malfunction table.....	154	Safety.....	13
Malfunctions.....	153	Commissioning.....	145
Master.....	131	Electrical connection.....	82
Menu setup.....	177	Maintenance.....	149
MHTM™ MicroDrive service specialists.....	16	Malfunctions.....	153
Modifications.....	15	Operation.....	145
Motorcycle loops.....	41	Repair.....	163
Mounting material		Transport.....	35
Requirements.....	57, 59	Safety devices	
N		Plausibility check.....	88
Nesting post.....	33	Safety light barrier.....	60
Non-intended use.....	14	Scope of delivery.....	11
O		Service switch.....	116
Occupational safety.....	17, 18	Setup	
Open/Closed button.....	110	Programme mode.....	106
Operating Instructions.....	8	Slave.....	131
Operating personnel		Spare parts.....	164
Requirements.....	16	Specialised staff.....	16
Operational view.....	100	Specialists	
Output relay.....	94	Requirements.....	16
P		Storage.....	37
Parallel operation.....	131	Switching off.....	147
Parameterising		Switching on.....	147
Options.....	104	Symbols	
Values.....	105	Control button functions.....	101
Passenger car loops.....	38, 39, 41	Current programme mode.....	103
Pendulum support.....	33	Current state of the barrier.....	102
Personal protective equipment.....	17	Current state of the induction loops.....	103
Pictogram explanation.....	9	Further.....	103
Programme mode		T	
Deadman.....	108	Technical data	
Maintained contact.....	107	Access XL.....	27
Pulse control.....	109	Access XXL.....	29
Two-pulse control.....	110	Transport.....	37
Prohibition signs.....	81	Transport inspection.....	36
R		Type code.....	26
Radio plug-in module		Type plate.....	25
Technical data.....	32	U	
Reinforcement.....	45, 46, 47, 48	Unpacking.....	57
Access XL.....	46	W	
Access XXL.....	49	Warning notes.....	9
Reset barrier.....	161	Warranty.....	11

MAGNETIC Autocontrol GmbH
Grienmatt 20
79650 Schopfheim
Germany

Address sales partner:

Tel.: +49 (0)76 22 695 5
Fax: +49 (0)76 22 695 602
E-Mail: info@ac-magnetic.com
Internet: www.ac-magnetic.com



F05483253